



TOUGHMesh

- Submittals -

(Bulk Package)

6

5

4

3

2

1

F

F

E

E

D

D

C

C

B

B

A

A

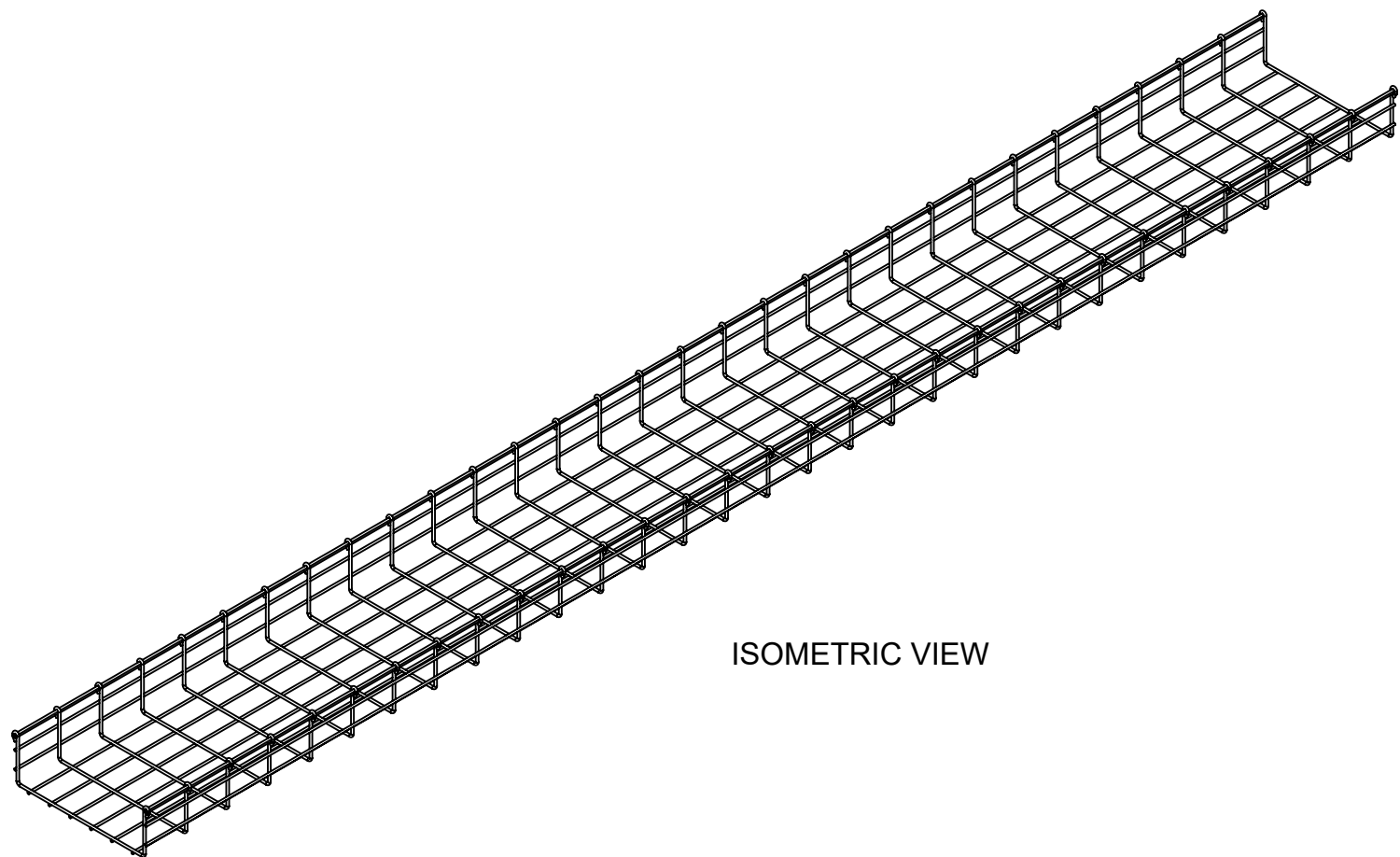

ISOMETRIC VIEW

TMS - 4 X 12 X 10 - TG

SERIES
TMS = TOUGHMESH
STRAIGHT SECTION

NOMINAL
HEIGHT (H)
2 = 2"
4 = 4"
6 = 6"

NOMINAL
WIDTH (W)
02 = 2"
04 = 4"
06 = 6"
08 = 8"
10 = 10"
12 = 12"
16 = 16"
18 = 18"
20 = 20"
24 = 24"

NOMINAL
LENGTH
10 = 120"

(*) MATERIAL/ FINISH
EG = ELECTROPLATED ZINC
PT = PAINTED FINISH
S4 = STAINLESS STEEL 304
TG = TOUGH GALVANIZED
S6 = STAINLESS STEEL 316

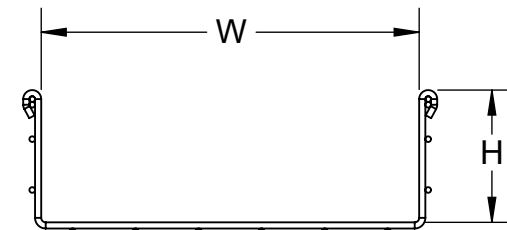

SECTION VIEW

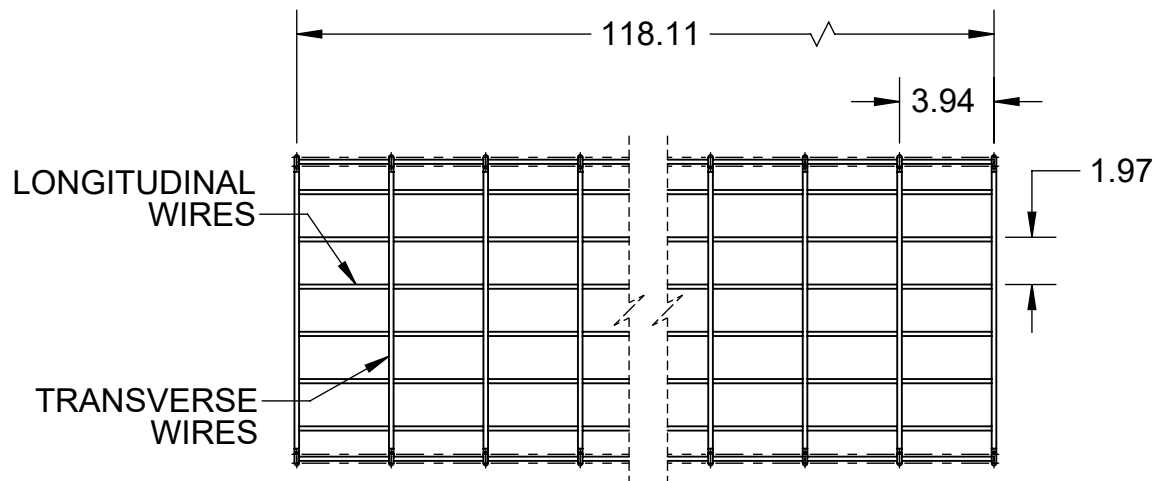

TOP VIEW

NOTE(S):

- 1) DIMENSIONS SHOWN ARE IN INCHES UNLESS OTHERWISE NOTED.
- 2) ALL DIMENSIONS SHOWN ARE NOMINAL.

PROPRIETARY AND CONFIDENTIAL THE INFORMATION CONTAINED IN THIS DRAWING IS THE SOLE PROPERTY OF CT INNOVATIONS. ANY REPRODUCTION IN PART OR AS A WHOLE WITHOUT THE WRITTEN PERMISSION OF CT INNOVATIONS IS PROHIBITED.

 CT INNOVATIONS	TITLE: TOUGHMESH STRAIGHT SECTION TMS-(H)X(W)X10-(*)		
	DRAWN BY/DATE: LW 10NOV2023	SIZE: B	DWG. NO.: CTI-S31999
APPROVED BY/DATE:	SCALE: NTS	CAD FILE NAME: TMS-4X12X10_A CAD SAVE DATE: Friday, July 28, 2023 3:28:23 PM	SHEET: 1 OF 1

6

5

4

3

2

1

6

5

4

3

2

1

F

F

E

E

D

D

C

C

B

B

A

A

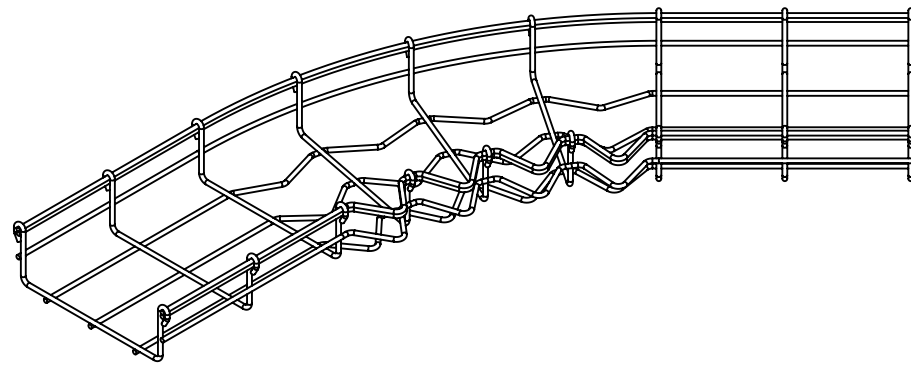

ISOMETRIC VIEW

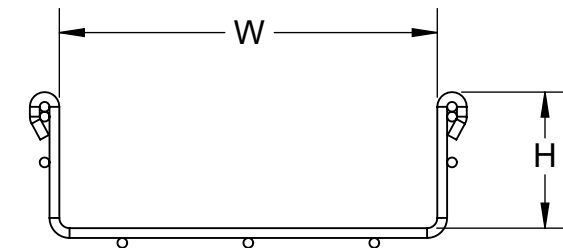

SECTION VIEW

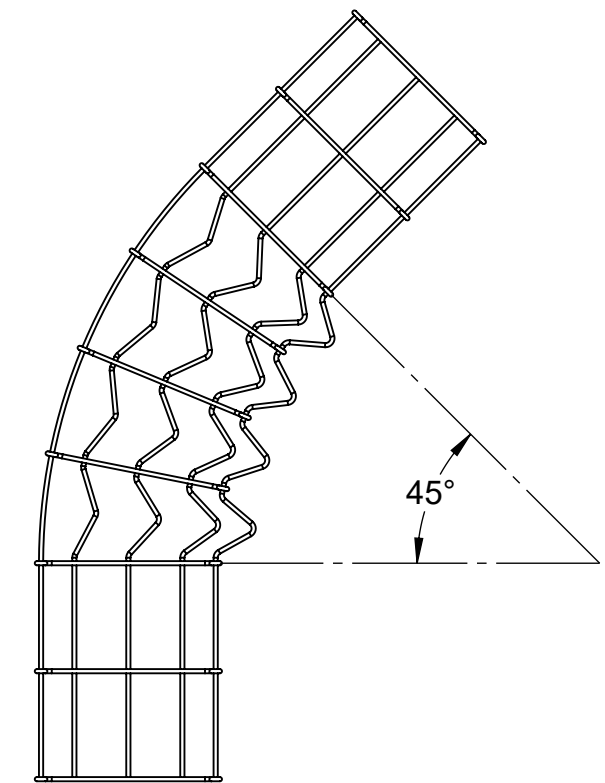

TOP VIEW

TMF - 4 X 12 - 45HB - TG

SERIES
TMF = TOUGHMESH
FITTINGS

NOMINAL
HEIGHT (H)
2 = 2"
4 = 4"
6 = 6"

NOMINAL
WIDTH (W)
02 = 2"
04 = 4"
06 = 6"
08 = 8"
10 = 10"
12 = 12"
16 = 16"
18 = 18"
20 = 20"

TYPE
45HB = 45°
HORIZONTAL
BEND

(*) MATERIAL/ FINISH
EG = ELECTROPLATED ZINC
PT = PAINTED FINISH
S4 = STAINLESS STEEL 304
TG = TOUGH GALVANIZED
S6 = STAINLESS STEEL 316

NOTE(S):

- 1) DIMENSIONS SHOWN ARE IN INCHES UNLESS OTHERWISE NOTED.
- 2) ALL DIMENSIONS SHOWN ARE NOMINAL.

PROPRIETARY AND CONFIDENTIAL THE INFORMATION CONTAINED IN THIS DRAWING IS THE SOLE PROPERTY OF CT INNOVATIONS. ANY REPRODUCTION IN PART OR AS A WHOLE WITHOUT THE WRITTEN PERMISSION OF CT INNOVATIONS IS PROHIBITED.

 CT INNOVATIONS	TITLE: TOUGHMESH 45° HORIZONTAL BEND TMF-(H)X(W)-45HB-(*)		
	DRAWN BY/DATE: LW 29NOV2023	SIZE: B	DWG. NO.: CTI-S33999
APPROVED BY/DATE: JDG 18JAN2023	SCALE: NTS	CAD FILE NAME: TMS-2X6X10_A CAD SAVE DATE: Wednesday, January 18, 2023 8:18:42 AM	SHEET: 1 OF 1

6

5

4

3

2

1

6

5

4

3

2

1

F

F

E

E

D

D

C

C

B

B

A

A

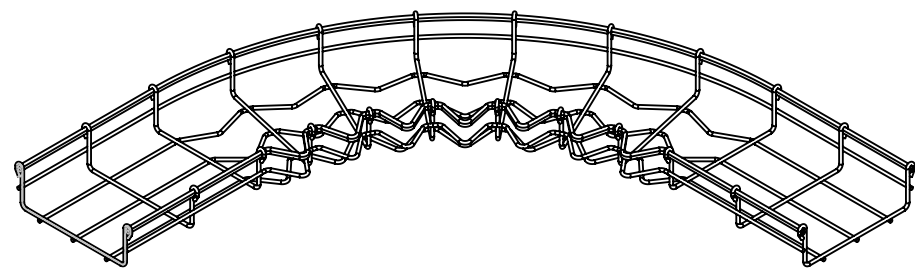

ISOMETRIC VIEW

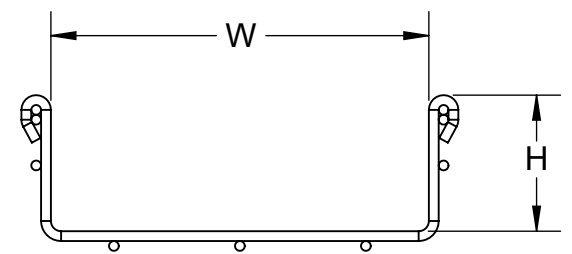

SECTION VIEW

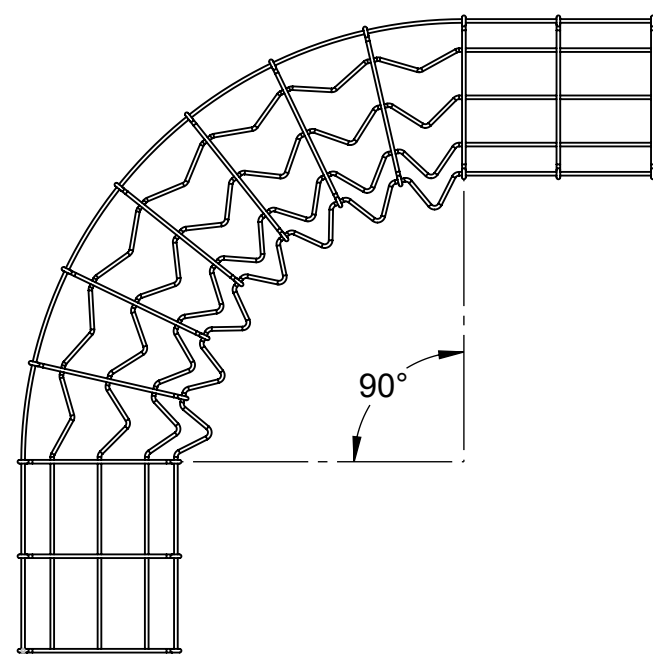

TOP VIEW

TMF - 4 X 12 - 90HB - TG

SERIES
TMF = TOUGHMESH
FITTINGS

NOMINAL
HEIGHT (H)
2 = 2"
4 = 4"
6 = 6"

NOMINAL
WIDTH (W)
02 = 2"
04 = 4"
06 = 6"
08 = 8"
10 = 10"
12 = 12"
16 = 16"
18 = 18"
20 = 20"

TYPE
90HB = 90°
HORIZONTAL
BEND

(*) MATERIAL/ FINISH
EG = ELECTROPLATED ZINC
PT = PAINTED FINISH
S4 = STAINLESS STEEL 304
TG = TOUGH GALVANIZED
S6 = STAINLESS STEEL 316

NOTE(S):

- 1) DIMENSIONS SHOWN ARE IN INCHES UNLESS OTHERWISE NOTED.
- 2) ALL DIMENSIONS SHOWN ARE NOMINAL.

PROPRIETARY AND CONFIDENTIAL THE INFORMATION CONTAINED IN THIS DRAWING IS THE SOLE PROPERTY OF CT INNOVATIONS. ANY REPRODUCTION IN PART OR AS A WHOLE WITHOUT THE WRITTEN PERMISSION OF CT INNOVATIONS IS PROHIBITED.

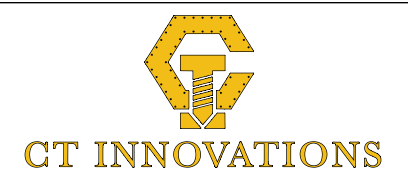

TITLE:
TOUGHMESH 90° HORIZONTAL BEND
TMF-(H)X(W)-90HB-(*)

DRAWN BY/DATE:
LW 29NOV2023

SIZE: **B** DWG. NO.: **CTI-S32999** REV: **B**

APPROVED BY/DATE:
JDG 18JAN2023

SCALE: **NTS** CAD FILE NAME: TMS-2X6X10_A SHEET: **1 OF 1**
CAD SAVE DATE: Wednesday, January 18, 2023 8:18:44 AM

6

5

4

3

2

1

6

5

4

3

2

1

F

F

E

E

D

D

C

C

B

B

A

A

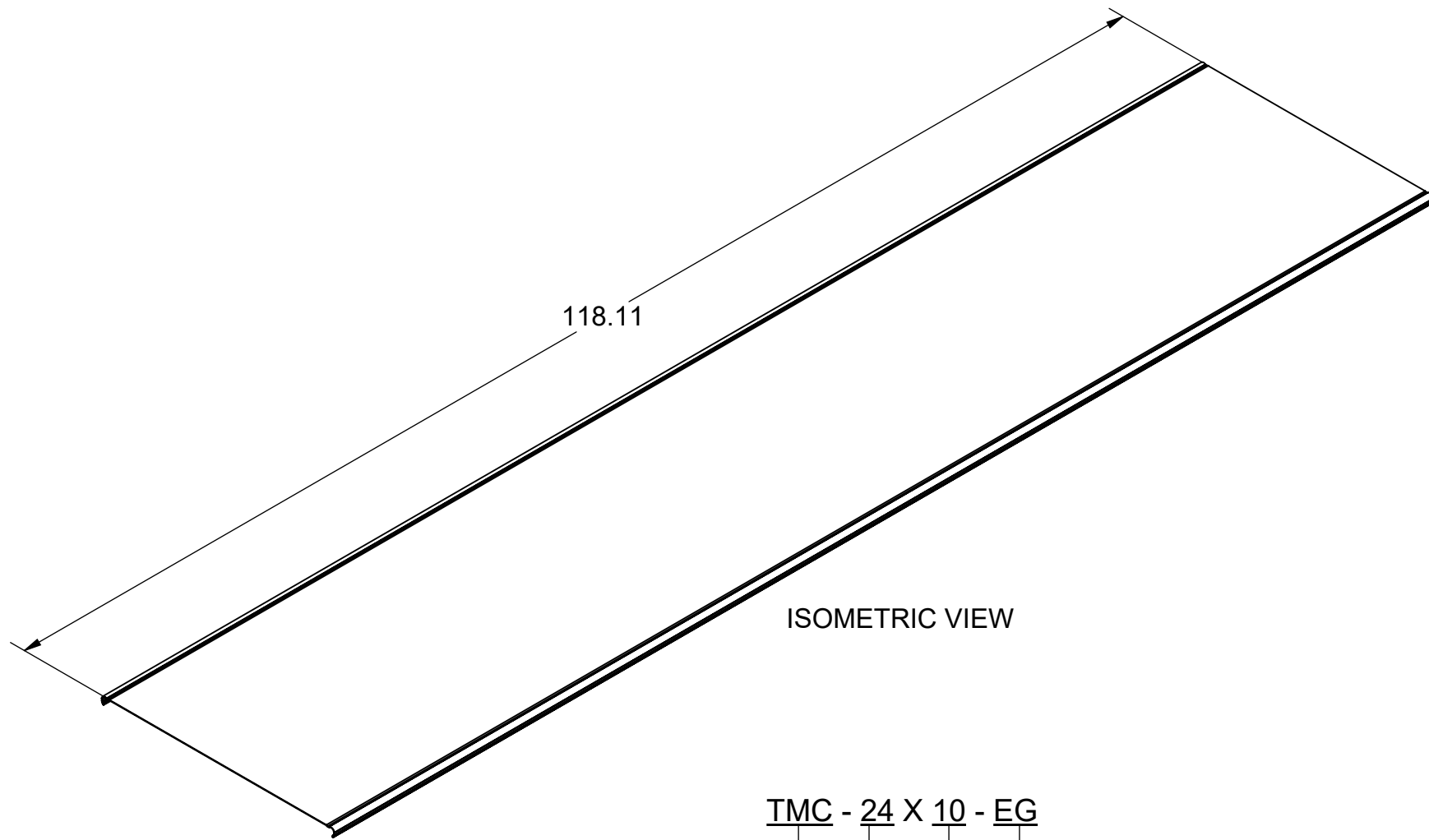

118.11

ISOMETRIC VIEW

TMC SERIES
STRAIGHT
SECTION COVER

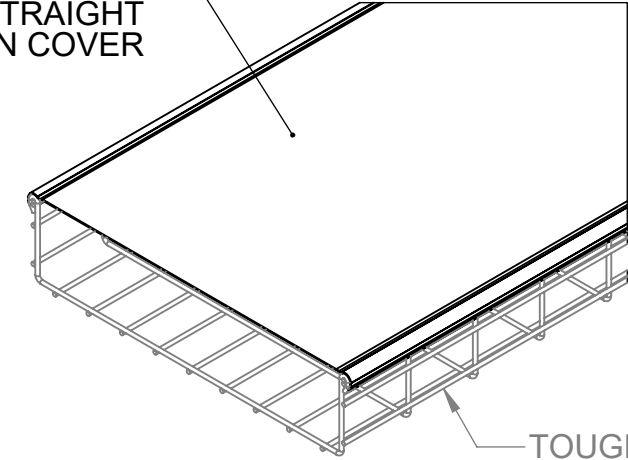

TOUGHMESH TRAY
(NOT INCLUDED)

ISO INSTALLED VIEW

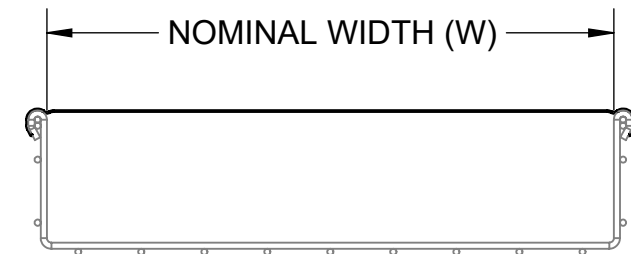

NOMINAL WIDTH (W)

SECTION VIEW

TMC - 24 X 10 - EG

SERIES
TMC = TOUGHMESH
STRAIGHT SECTION
COVER

NOMINAL WIDTH (W)
 02 = 2" 12 = 12"
 04 = 4" 16 = 16"
 06 = 6" 18 = 18"
 08 = 8" 20 = 20"
 10 = 10" 24 = 24"

NOMINAL
LENGTH
10 = 120"

(*) MATERIAL/ FINISH
 EG = ELECTROPLATED ZINC
 PT = PAINTED
 HD = HOT-DIPPED GALVANIZED
 S4 = STAINLESS STEEL 304
 S6 = STAINLESS STEEL 316

NOTE(S):

- 1) DIMENSIONS SHOWN ARE IN INCHES UNLESS OTHERWISE NOTED.
- 2) ALL DIMENSIONS SHOWN ARE NOMINAL.

PROPRIETARY AND CONFIDENTIAL THE INFORMATION CONTAINED IN THIS DRAWING IS THE SOLE PROPERTY OF CT INNOVATIONS. ANY REPRODUCTION IN PART OR AS A WHOLE WITHOUT THE WRITTEN PERMISSION OF CT INNOVATIONS IS PROHIBITED.

 CT INNOVATIONS		TITLE: TOUGHMESH STRAIGHT SECTION COVER TMC-(W)X10-(*)		
		DRAWN BY/DATE: LW 28JUL2023	SIZE: B	DWG. NO.: CTI-S34999
APPROVED BY/DATE: JDG 31JUL2023		SCALE: NTS	CAD FILE NAME: CTI-S34001_A01 CAD SAVE DATE: Friday, July 28, 2023 5:24:57 PM	SHEET: 1 OF 1

6

5

4

3

2

1

6

5

4

3

2

1

SPLICE CHART (UL Classified)

TRAY SIZE H X W (in)	POSI-LOK SPLICE QTY TMA-PLOK-(*)
2X12	2
2X16	2
2X18	2
2X20	2
2X24	2
4X12	2
4X16	2
4X18	2
4X20	2
4X24	2
6X12	2
6X16	2
6X18	2
6X20	2
6X24	2

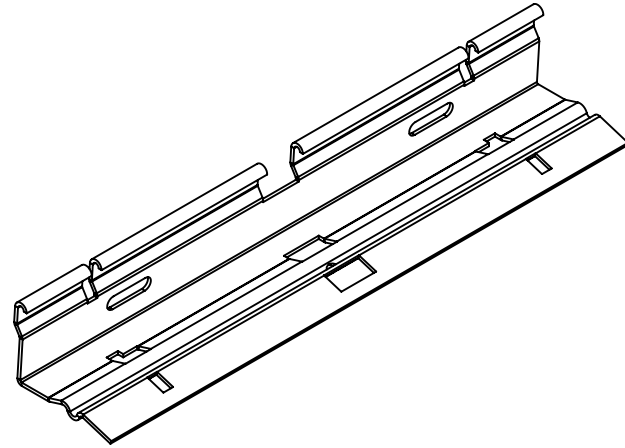

ISOMETRIC VIEW

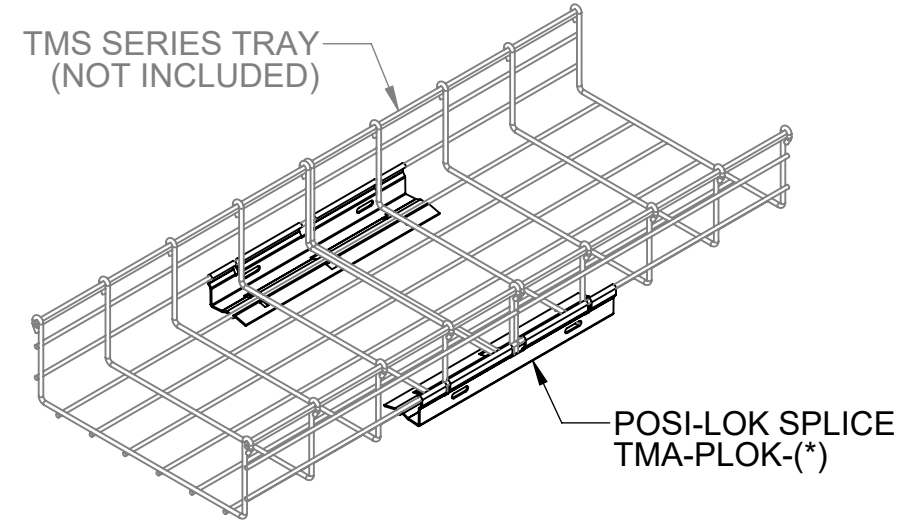

ISO INSTALLED VIEW

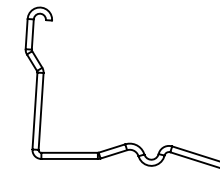
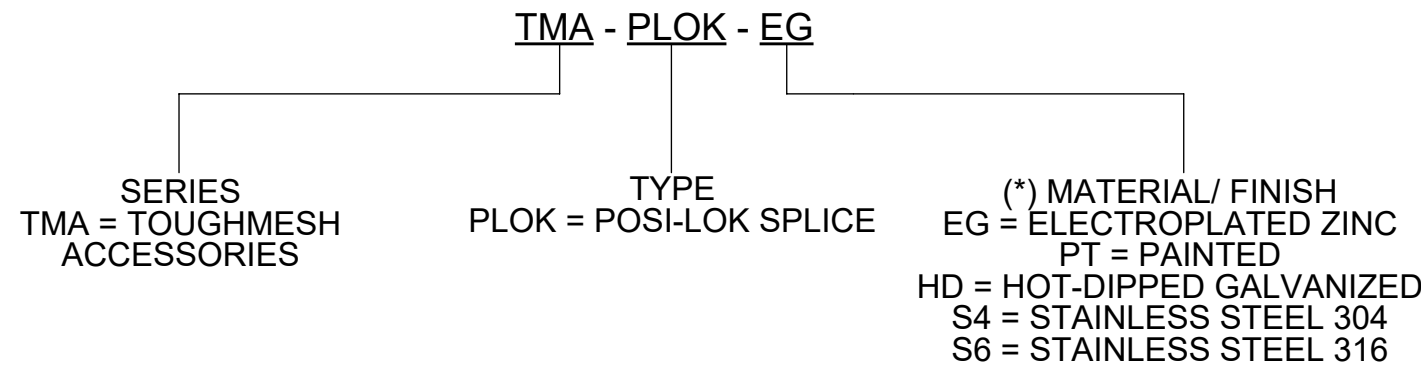

SECTION VIEW

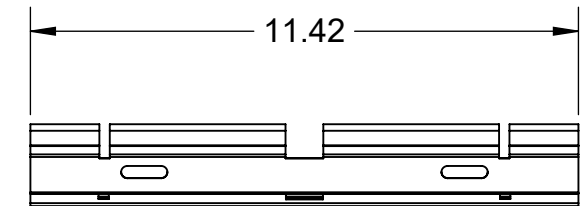

SIDE VIEW

NOTE(S):

- 1) DIMENSIONS SHOWN ARE IN INCHES UNLESS OTHERWISE NOTED.
- 2) ALL DIMENSIONS SHOWN ARE NOMINAL.
- 3) SPLICE PLATE USED FOR 2~6" HEIGHT & 12~24" WIDTH. REFER TO SPLICE CHART FOR FOR UL CLASSIFIED POSI-LOK SPLICE QUANTITY.
- 4) SOLD IN PAIRS.

PROPRIETARY AND CONFIDENTIAL THE INFORMATION CONTAINED IN THIS DRAWING IS THE SOLE PROPERTY OF CT INNOVATIONS. ANY REPRODUCTION IN PART OR AS A WHOLE WITHOUT THE WRITTEN PERMISSION OF CT INNOVATIONS IS PROHIBITED.

	TITLE: TOUGHMESH POSI-LOK SPLICE TMA-PLOK-(*)		
	DRAWN BY/DATE: LW 21OCT2024	SIZE: B	DWG. NO.: CTI-S37001
APPROVED BY/DATE:	SCALE: NTS	CAD FILE NAME: TMA-PLOK_A CAD SAVE DATE: Monday, October 21, 2024 1:47:22 PM	SHEET: 1 OF 1

6

5

4

3

2

1

6

5

4

3

2

1

SPLICE CHART (UL CLASSIFIED)	
TRAY SIZE H X W (IN)	POSI-LOK MINI SPLICE QTY TMA-PLOK-(*)
2X2	2
2X4	2
2X6	2
2X8	2
2X10	2
4X4	2
4X6	2
4X8	2
4X10	2
6X8	2
6X10	2

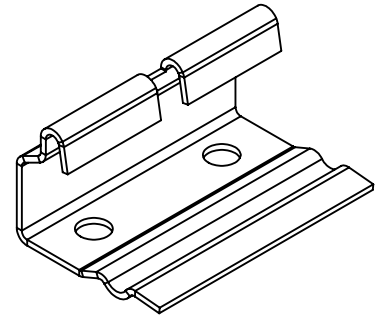

ISOMETRIC VIEW

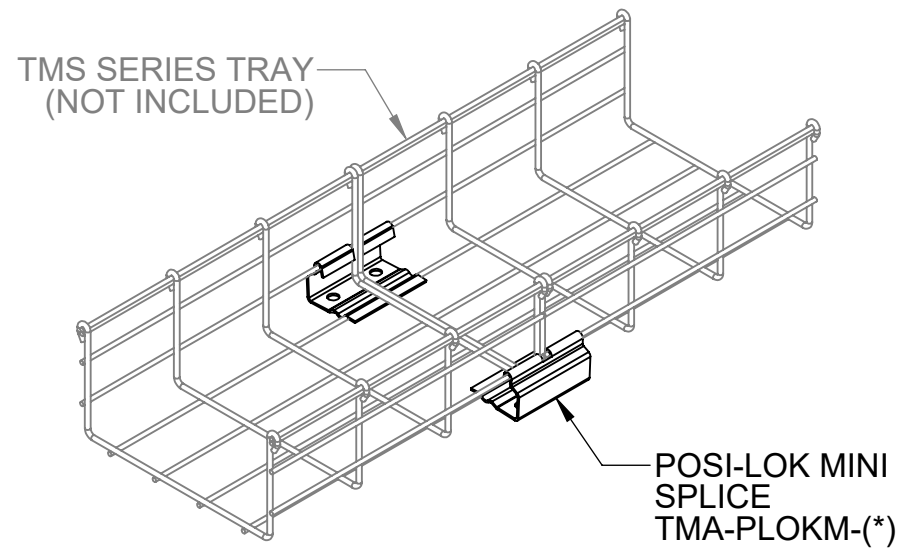

ISO INSTALLED VIEW

TMA - PLOKM - EG

SERIES
TMA = TOUGHMESH
ACCESSORIES

TYPE
PLOKM = POSI-LOK
MINI SPLICE

(*) MATERIAL/ FINISH
EG = ELECTROPLATED ZINC
PT = PAINTED
HD = HOT-DIPPED GALVANIZED
S4 = STAINLESS STEEL 304
S6 = STAINLESS STEEL 316

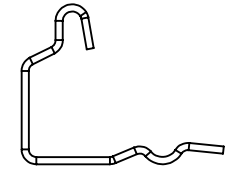

SECTION VIEW

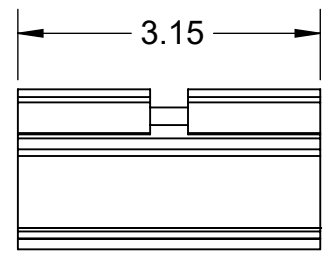

SIDE VIEW

NOTE(S):
 1) DIMENSIONS SHOWN ARE IN INCHES UNLESS OTHERWISE NOTED.
 2) ALL DIMENSIONS SHOWN ARE NOMINAL.
 3) SPLICE PLATE USED FOR 2~6" HEIGHT & 2~10" WIDTH. REFER TO SPLICE CHART FOR UL CLASSIFIED POSI-LOK MINI SPLICE QUANTITY.
 4) SOLD IN PAIRS.

PROPRIETARY AND CONFIDENTIAL THE INFORMATION CONTAINED IN THIS DRAWING IS THE SOLE PROPERTY OF CT INNOVATIONS. ANY REPRODUCTION IN PART OR AS A WHOLE WITHOUT THE WRITTEN PERMISSION OF CT INNOVATIONS IS PROHIBITED.

	TITLE: TOUGHMESH POSI-LOK MINI SPLICE TMA-PLOKM-(*)			
	DRAWN BY/DATE: LW 28JUL2023	SIZE: B	DWG. NO.: CTI-S37002	REV: B
	APPROVED BY/DATE:	SCALE: NTS	CAD FILE NAME: CTI-S37002_B CAD SAVE DATE: Tuesday, August 15, 2023 2:21:09 PM	SHEET: 1 OF 1

6

5

4

3

2

1

SPLICE CHART (UL Classified)		
TRAY SIZE H X W (in)	WASHER SPLICE KIT QTY	
	SIDERAIL	BOTTOM
2X2	2	0
2X4	2	0
2X6	2	0
2X8	2	1
2X10	2	1
2X12	2	1
2X16	2	2
2X18	2	2
2X20	2	2
2X24	2	2
4X4	2	2
4X6	2	2
4X8	2	3
4X10	2	3
4X12	2	4
4X16	2	4
4X18	2	4
4X20	2	5
4X24	2	5
6X8	4	2
6X10	4	2
6X12	4	3
6X16	4	3
6X18	4	3
6X20	4	4
6X24	4	4

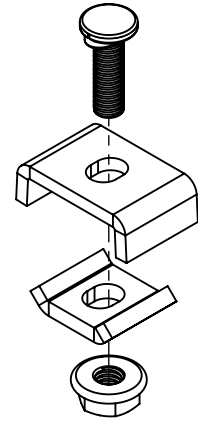

ISOMETRIC VIEW

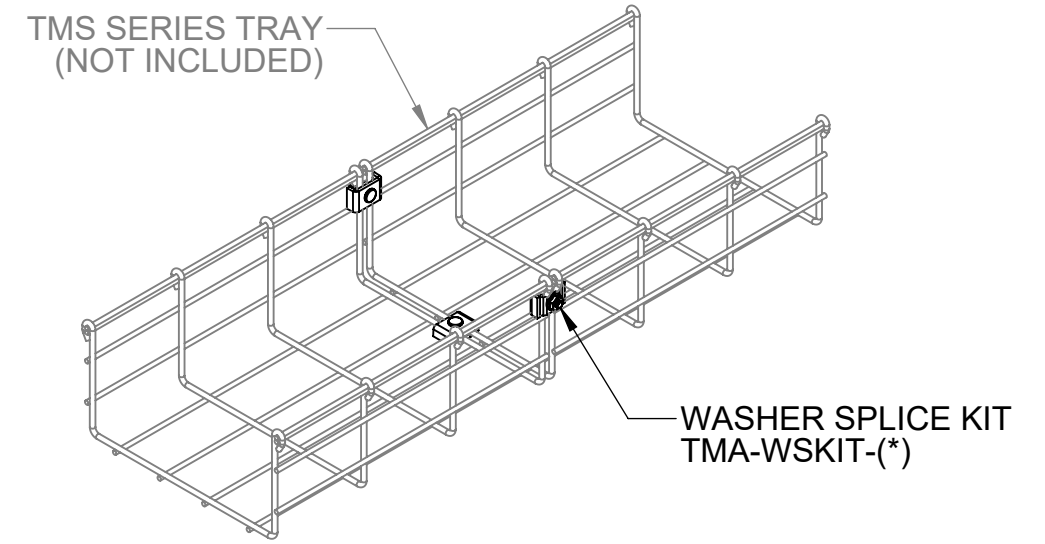

ISO INSTALLED VIEW

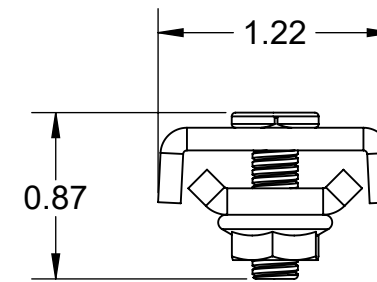
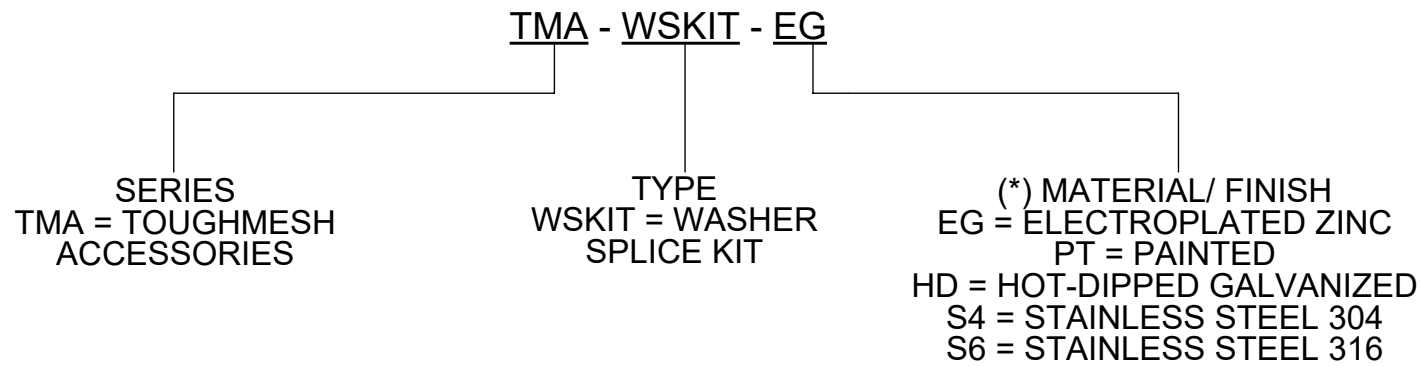

SECTION VIEW

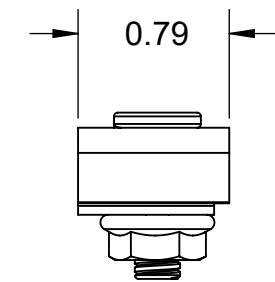

SIDE VIEW

- NOTE(S):**
- 1) DIMENSIONS SHOWN ARE IN INCHES UNLESS OTHERWISE NOTED.
 - 2) ALL DIMENSIONS SHOWN ARE NOMINAL.
 - 3) SPLICE PLATE USED FOR 2~6" HEIGHT & 2~24" WIDTH. REFER TO SPLICE CHART FOR UL CLASSIFIED WASHER SPLICE KIT QUANTITY.
 - 4) SOLD IN BAG OF 50.

PROPRIETARY AND CONFIDENTIAL THE INFORMATION CONTAINED IN THIS DRAWING IS THE SOLE PROPERTY OF CT INNOVATIONS. ANY REPRODUCTION IN PART OR AS A WHOLE WITHOUT THE WRITTEN PERMISSION OF CT INNOVATIONS IS PROHIBITED.

	TITLE: TOUGHMESH WASHER SPLICE KIT TMA-WSKIT-(*)			
	DRAWN BY/DATE: LW 21OCT2024	SIZE: B	DWG. NO.: CTI-S37003	REV: C
	APPROVED BY/DATE:	SCALE: NTS	CAD FILE NAME: TMA-WSKIT_A CAD SAVE DATE: Monday, October 21, 2024 1:50:03 PM	SHEET: 1 OF 1

6

5

4

3

2

1

F

F

E

E

D

D

C

C

B

B

A

A

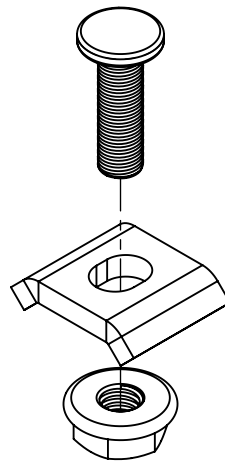

ISOMETRIC VIEW

TMA - HDKIT - EG

SERIES
TMA = TOUGHMESH
ACCESSORIES

TYPE
HDKIT = HOLD
DOWN KIT

(*) MATERIAL/ FINISH
EG = ELECTROPLATED ZINC
PT = PAINTED
HD = HOT-DIPPED GALVANIZED
S4 = STAINLESS STEEL 304
S6 = STAINLESS STEEL 316

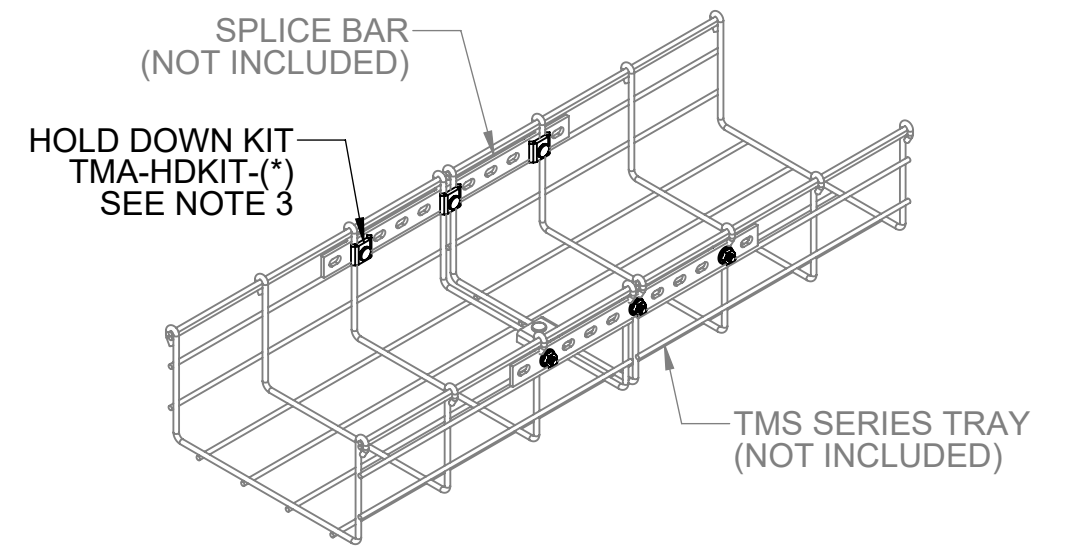

ISO INSTALLED VIEW

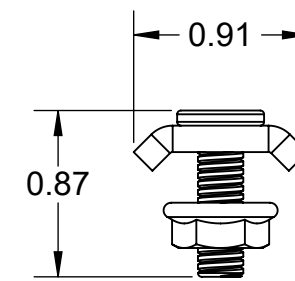

SECTION VIEW

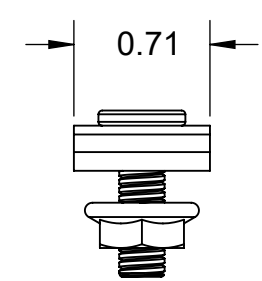

SIDE VIEW

NOTE(S):

- 1) DIMENSIONS SHOWN ARE IN INCHES UNLESS OTHERWISE NOTED.
- 2) ALL DIMENSIONS SHOWN ARE NOMINAL.
- 3) USED TO SECURE EXPANSION SPLICE AND SPLICE BAR TO THE BASKET TRAY SIDERAIL. REFER TO SPLICE CHART TABLE IN DRAWING CTI-S37006, CTI-S37007 & CTI-S37008 FOR QUANTITY REQUIRED.
- 4) SOLD IN BAG OF 50.

PROPRIETARY AND CONFIDENTIAL THE INFORMATION CONTAINED IN THIS DRAWING IS THE SOLE PROPERTY OF CT INNOVATIONS. ANY REPRODUCTION IN PART OR AS A WHOLE WITHOUT THE WRITTEN PERMISSION OF CT INNOVATIONS IS PROHIBITED.

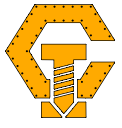
 CT INNOVATIONS	TITLE: TOUGHMESH HOLD DOWN KIT TMA-HDKIT-(*)			
	DRAWN BY/DATE: LW 21OCT2024	SIZE: B	DWG. NO.: CTI-S37004	REV: C
	APPROVED BY/DATE:	SCALE: NTS	CAD FILE NAME: CTI-S37004_C CAD SAVE DATE: Monday, October 21, 2024 1:58:35 PM	SHEET: 1 OF 1

6

5

4

3

2

1

6

5

4

3

2

1

SPLICE CHART

TRAY SIZE H X W (in)	SPLICE BAR QTY TMA-SB-(*)	WASHER SPLICE KIT QTY TMA-WSKIT-(*)	HOLD DOWN KIT QTY TMA-HDKIT-(*)
2X2	2	0	6
2X4	2	0	6
2X6	2	0	6
2X8	2	0	6
2X10	2	1	6
2X12	2	1	6
2X16	2	1	6
2X18	2	2	6
2X20	2	2	6
2X24	2	2	6
4X4	2	0	6
4X6	2	0	6
4X8	2	0	6
4X10	2	1	6
4X12	2	1	6
4X16	2	1	6
4X18	2	2	6
4X20	2	2	6
4X24	2	2	6
6X8	2	0	6
6X10	2	1	6
6X12	2	1	6
6X16	2	1	6
6X18	2	2	6
6X20	2	2	6
6X24	2	2	6

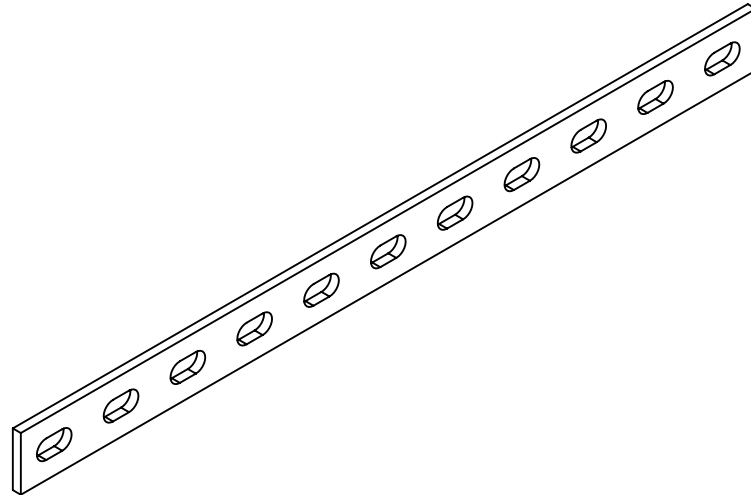

ISOMETRIC VIEW

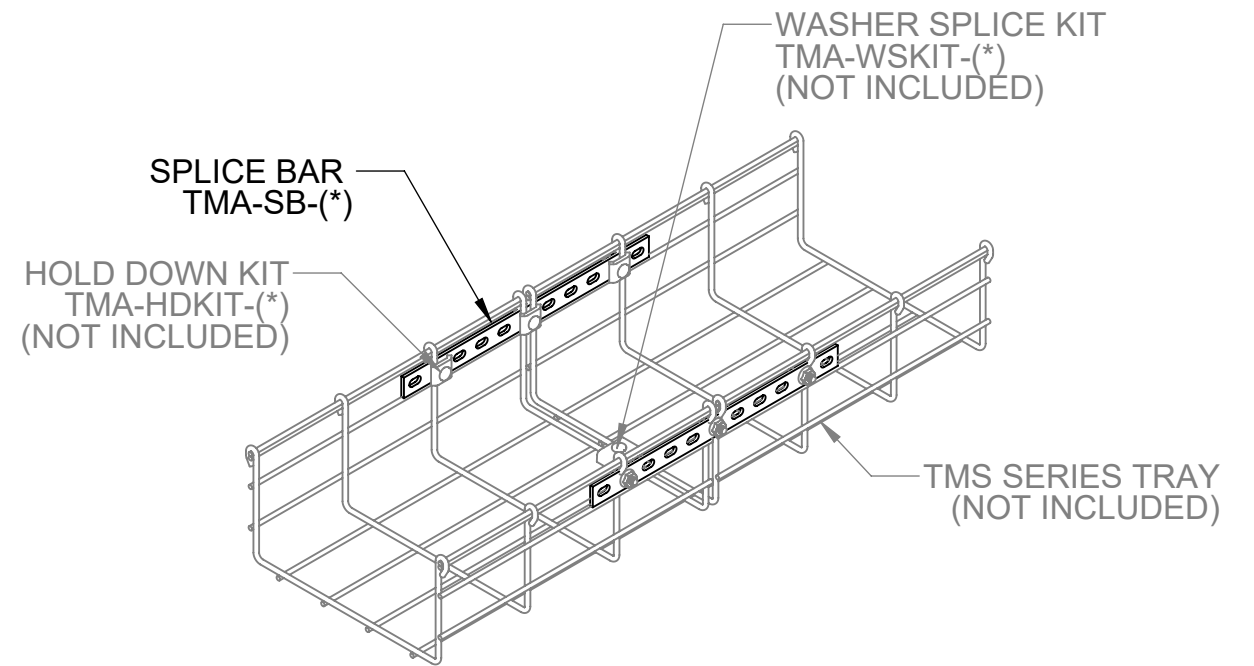

ISO INSTALLED VIEW

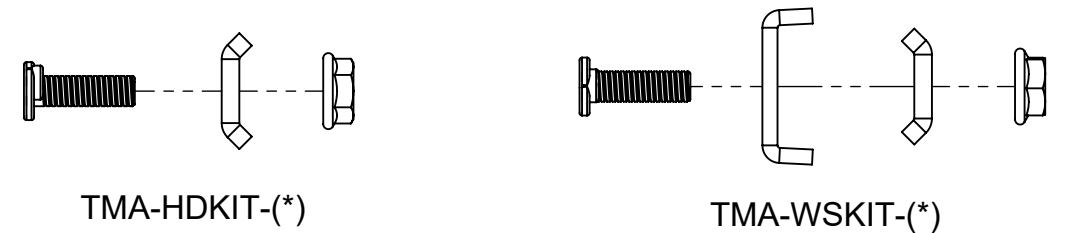

TMA-HDKIT-(*)

TMA-WSKIT-(*)

HARDWARE TO BE ORDERED SEPARATELY
(SEE NOTE 5)

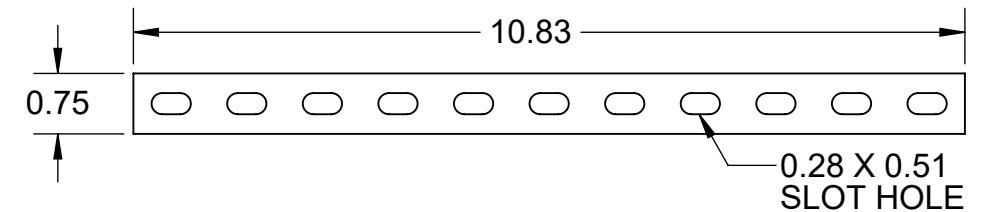

SIDE VIEW

TMA - SB - EG

SERIES
TMA = TOUGHMESH
ACCESSORIES

TYPE
SB = SPLICE BAR

(*) MATERIAL/ FINISH
EG = ELECTROPLATED ZINC
PT = PAINTED
HD = HOT-DIPPED GALVANIZED
S4 = STAINLESS STEEL 304
S6 = STAINLESS STEEL 316

NOTE(S):

- 1) DIMENSIONS SHOWN ARE IN INCHES UNLESS OTHERWISE NOTED.
- 2) ALL DIMENSIONS SHOWN ARE NOMINAL.
- 3) SPLICE BAR KIT USED FOR 2~6" HEIGHT & 2~24" WIDTH.
- 4) SOLD IN PAIRS.
- 5) WASHER SPLICE KIT "TMA-WSKIT-(*)" AND HOLD DOWN KIT "TMA-HDKIT-(*)" TO BE ORDERED SEPARATELY. REFER TO SPLICE CHART FOR THE REQUIRED QUANTITY.

PROPRIETARY AND CONFIDENTIAL THE INFORMATION CONTAINED IN THIS DRAWING IS THE SOLE PROPERTY OF CT INNOVATIONS. ANY REPRODUCTION IN PART OR AS A WHOLE WITHOUT THE WRITTEN PERMISSION OF CT INNOVATIONS IS PROHIBITED.

	TITLE: TOUGHMESH SPLICE BAR TMA-SB-(*)		
	DRAWN BY/DATE: LW 30SEP2024	SIZE: B	DWG. NO.: CTI-S37005
	APPROVED BY/DATE:	SCALE: NTS	CAD FILE NAME: TMA-SBKIT_A CAD SAVE DATE: Monday, October 21, 2024 2:37:46 PM
REV: C		SHEET: 1 OF 1	

6

5

4

3

2

1

A

A

B

B

C

C

D

D

E

E

F

F

6

5

4

3

2

1

F

F

E

E

D

D

C

C

B

B

A

A

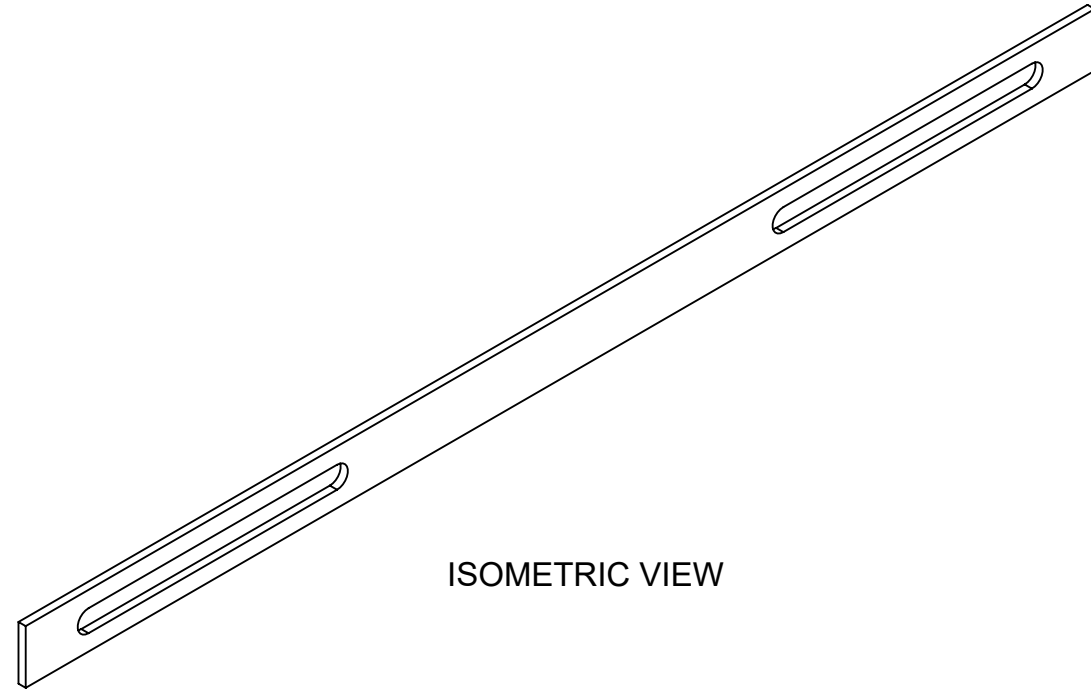

ISOMETRIC VIEW

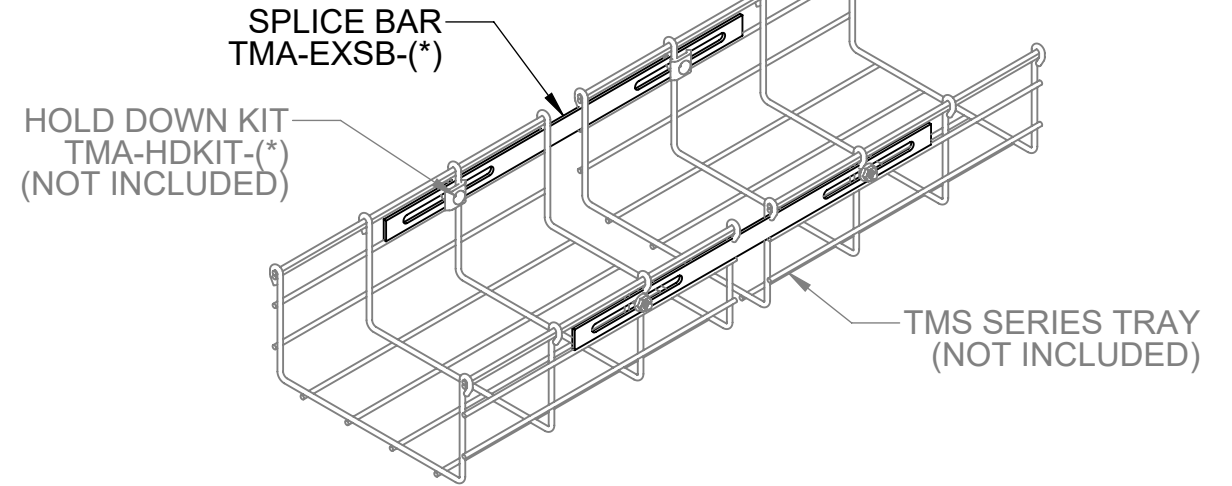

ISO INSTALLED VIEW

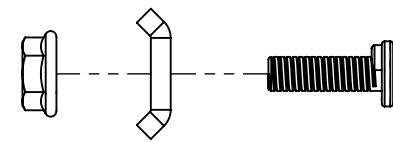

TMA-HDKIT-(*)
HARDWARE TO BE ORDERED SEPARATELY
(SEE NOTE 5)

TMA - EXSB - EG

SERIES
TMA = TOUGHMESH
ACCESSORIES

TYPE
EXSB= EXPANSION
SPLICE BAR

(*) MATERIAL/ FINISH
EG = ELECTROPLATED ZINC
PT = PAINTED
HD = HOT-DIPPED GALVANIZED
S4 = STAINLESS STEEL 304
S6 = STAINLESS STEEL 316

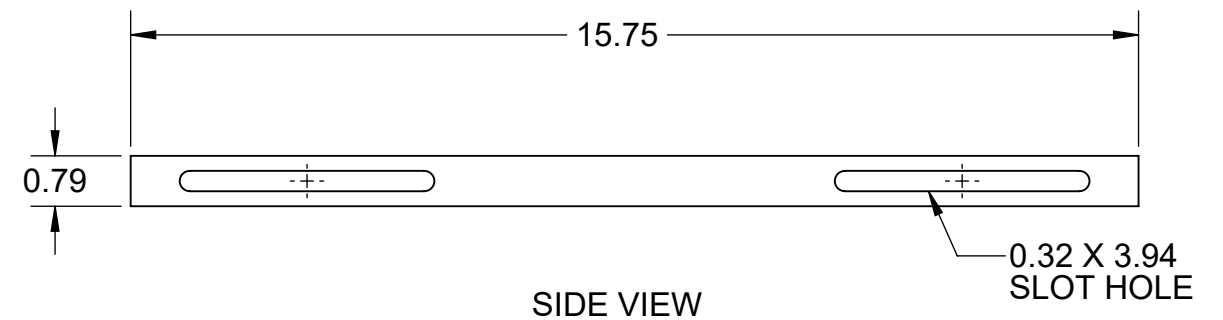

SIDE VIEW

NOTE(S):

- 1) DIMENSIONS SHOWN ARE IN INCHES UNLESS OTHERWISE NOTED.
- 2) ALL DIMENSIONS SHOWN ARE NOMINAL.
- 3) EXPANSION SPLICE BAR USED FOR 2~6" HEIGHT & 2~24" WIDTH TO ACCOUNT THERMAL EXPANSION/CONTRACTION.
- 4) SOLD IN PAIRS.
- 5) FOUR (4) PIECES HOLD DOWN KIT "TMA-HDKIT-(*)" TO BE ORDERED SEPARATELY.
- 6) REFER TO NEMA VE-2 SECTION 3.4.2 FOR INSTALLATION REQUIREMENTS.

PROPRIETARY AND CONFIDENTIAL THE INFORMATION CONTAINED IN THIS DRAWING IS THE SOLE PROPERTY OF CT INNOVATIONS. ANY REPRODUCTION IN PART OR AS A WHOLE WITHOUT THE WRITTEN PERMISSION OF CT INNOVATIONS IS PROHIBITED.

		TITLE:	
		TOUGHMESH EXPANSION SPLICE BAR TMA-EXSB-(*)	
DRAWN BY/DATE:	SIZE:	DWG. NO.:	REV:
LW 21OCT2024	B	CTI-S37006	C
APPROVED BY/DATE:	SCALE:	CAD FILE NAME: CTI-S37006_C	SHEET:
	NTS	CAD SAVE DATE: Tuesday, October 29, 2024 9:27:26 AM	1 OF 1

6

5

4

3

2

1

6

5

4

3

2

1

F

F

E

E

D

D

C

C

B

B

A

A

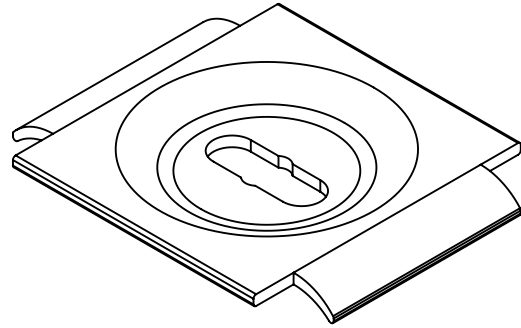

ISOMETRIC VIEW

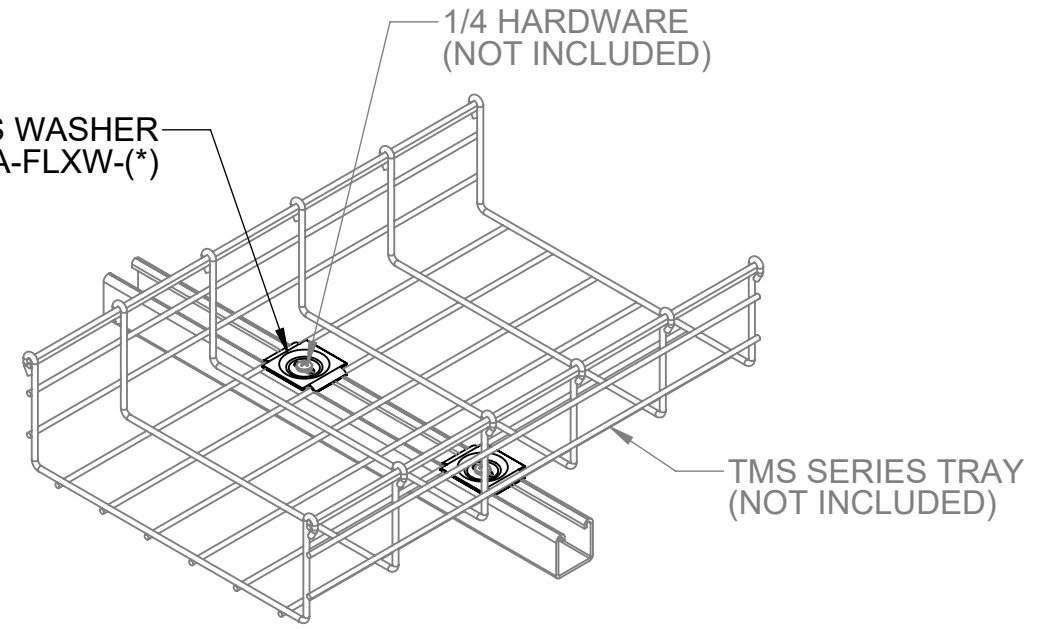

ISO INSTALLED VIEW

TMA - FLXW - EG

SERIES
TMA = TOUGHMESH ACCESSORIES

TYPE
FLXW = FLAT CROSS WASHER

(*) MATERIAL/ FINISH
EG = ELECTROPLATED ZINC
PT = PAINTED
HD = HOT-DIPPED GALVANIZED
S4 = STAINLESS STEEL 304
S6 = STAINLESS STEEL 316

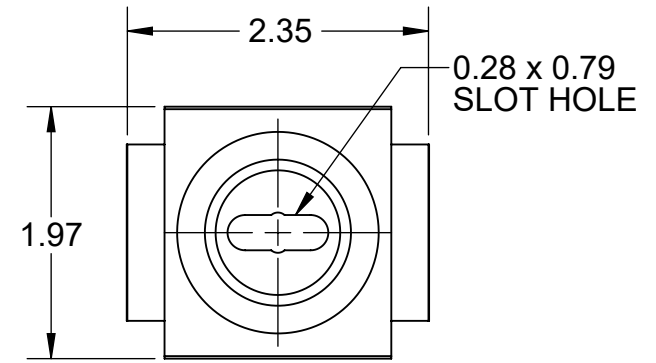

TOP VIEW

NOTE(S):

- 1) DIMENSIONS SHOWN ARE IN INCHES UNLESS OTHERWISE NOTED.
- 2) ALL DIMENSIONS SHOWN ARE NOMINAL.
- 3) USED TO SECURE BASKET TRAY TO THE SUPPORT.
- 4) 1/4 HARDWARE TO BE ORDERED SEPARATELY.
- 5) SOLD IN BAG OF 20.

PROPRIETARY AND CONFIDENTIAL THE INFORMATION CONTAINED IN THIS DRAWING IS THE SOLE PROPERTY OF CT INNOVATIONS. ANY REPRODUCTION IN PART OR AS A WHOLE WITHOUT THE WRITTEN PERMISSION OF CT INNOVATIONS IS PROHIBITED.

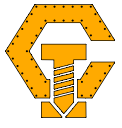
 CT INNOVATIONS	TITLE: TOUGHMESH FLAT CROSS WASHER TMA-FLXW-(*)			
	DRAWN BY/DATE: DL 21OCT2024	SIZE: B	DWG. NO.: CTI-S37009	REV: C
	APPROVED BY/DATE:	SCALE: NTS	CAD FILE NAME: CTI-S37009_C CAD SAVE DATE: Monday, October 21, 2024 3:09:36 PM	SHEET: 1 OF 1

6

5

4

3

2

1

6

5

4

3

2

1

PART NO.

DESCRIPTION

TMA-GRND

GROUND BOLT

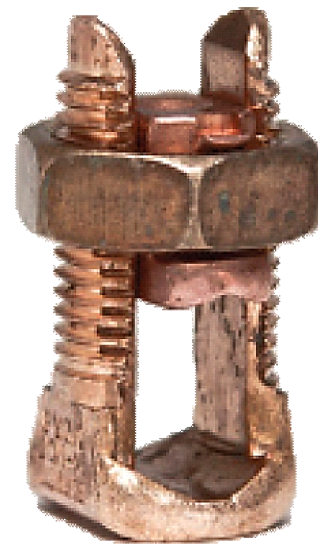

F

F

E

E

D

D

C

C

B

B

A

A

NOTES:

- 1) MATERIAL: TIN PLATED COPPER.
- 2) SOLD IN BAG OF 10.

PROPRIETARY AND CONFIDENTIAL THE INFORMATION CONTAINED IN THIS DRAWING IS THE SOLE PROPERTY OF CT INNOVATIONS. ANY REPRODUCTION IN PART OR AS A WHOLE WITHOUT THE WRITTEN PERMISSION OF CT INNOVATIONS IS PROHIBITED.

 CT INNOVATIONS	TITLE: TMA-GRND GROUND BOLT		
	DRAWN BY/DATE: LW 21OCT2024	SIZE: B	DWG. NO.: CTI-S37010
APPROVED BY/DATE:	SCALE: NTS	CAD FILE NAME: TA38NHX_A CAD SAVE DATE: Monday, October 21, 2024 3:11:47 PM	SHEET: 1 OF 1

6

5

4

3

2

1

TABLE 1						
TRAY WIDTH (in)	CORNER RADIUS QTY (PAIR) TMA-FLXW-(H)-(*)		WASHER SPLICE KIT QTY TMA-WSKIT-(*)		HOLD DOWN KIT QTY TMA-HDKIT-(*)	
	HORZ. TEE	HORZ. CROSS	HORZ. TEE	HORZ. CROSS	HORZ. TEE	HORZ. CROSS
4	1	2	1	2	8	16
6	1	2	2	4	8	16
8	1	2	2	4	8	16
10	1	2	2	4	8	16
12	1	2	2	4	8	16
16	1	2	2	4	8	16
18	1	2	2	4	8	16
20	1	2	2	4	8	16
24	1	2	2	4	8	16

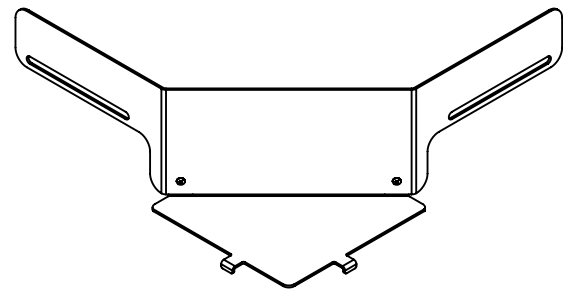

ISOMETRIC VIEW

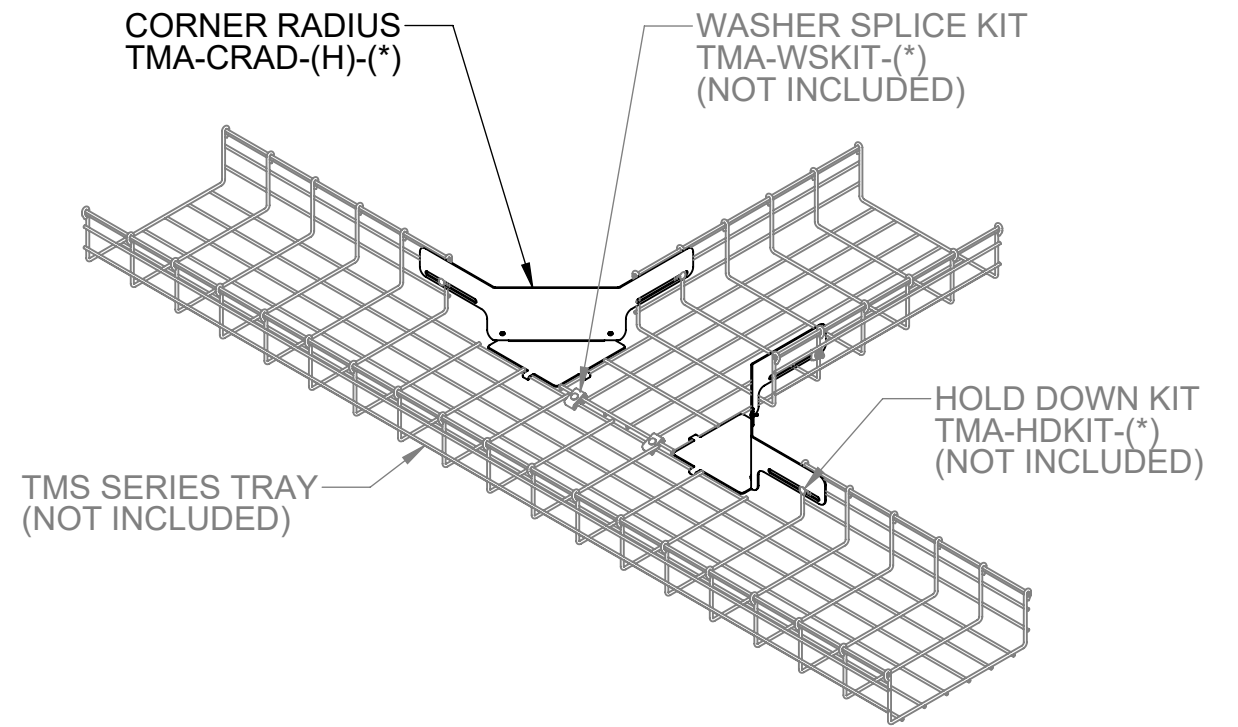
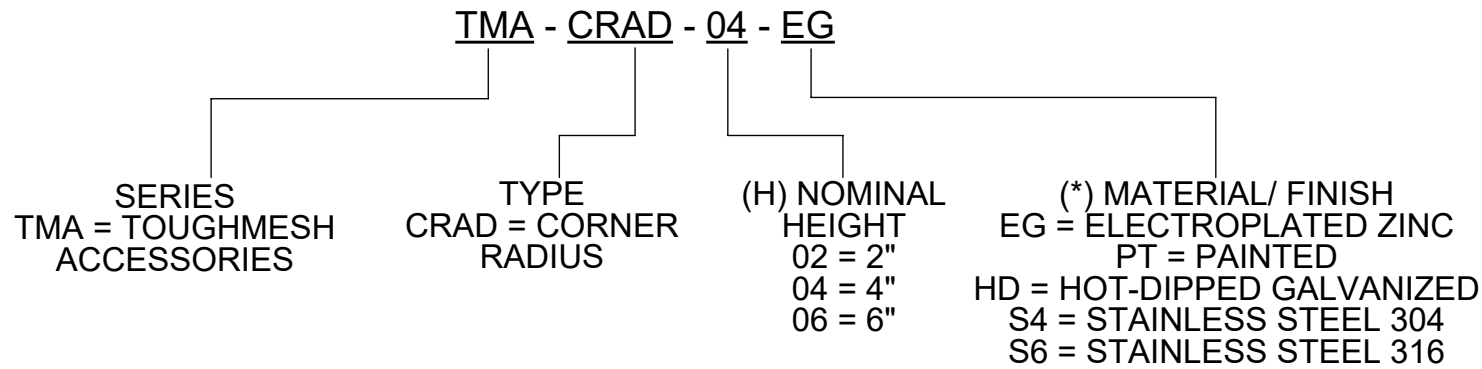

ISO INSTALLED VIEW

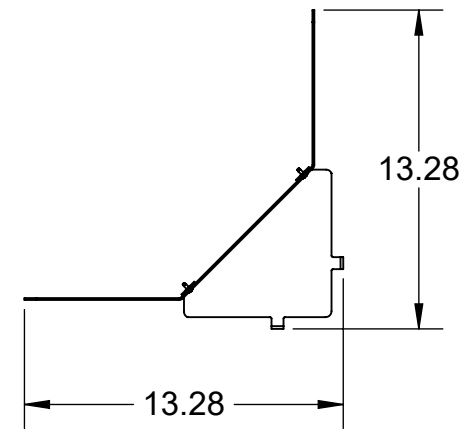

TOP VIEW

NOTE(S):

- 1) DIMENSIONS SHOWN ARE IN INCHES UNLESS OTHERWISE NOTED.
- 2) ALL DIMENSIONS SHOWN ARE NOMINAL.
- 3) SOLD IN PAIRS.
- 4) WASHER SPLICE KIT "TMA-WSKIT-(*)" AND HOLD DOWN KIT "TMA-HDKIT-(*)" TO BE ORDERED SEPARATELY. REFER TO TABLE 1 FOR THE REQUIRED QUANTITY.

<small>PROPRIETARY AND CONFIDENTIAL THE INFORMATION CONTAINED IN THIS DRAWING IS THE SOLE PROPERTY OF CT INNOVATIONS. ANY REPRODUCTION IN PART OR AS A WHOLE WITHOUT THE WRITTEN PERMISSION OF CT INNOVATIONS IS PROHIBITED.</small>				
	TITLE: TOUGHMESH CORNER RADIUS TMA-CRAD-(H)-(*)			
	DRAWN BY/DATE: LW 21OCT2024	SIZE: B	DWG. NO.: CTI-S37012	REV: C
	APPROVED BY/DATE:	SCALE: NTS	<small>CAD FILE NAME: CTI-S37012_C</small> <small>CAD SAVE DATE: Monday, October 21, 2024 3:18:27 PM</small>	SHEET: 1 OF 1

TRAY WIDTH (in)	LENGTH (in)
4	10
6	12
8	14
10	16
12	18
16	22
18	24
20	26
24	30

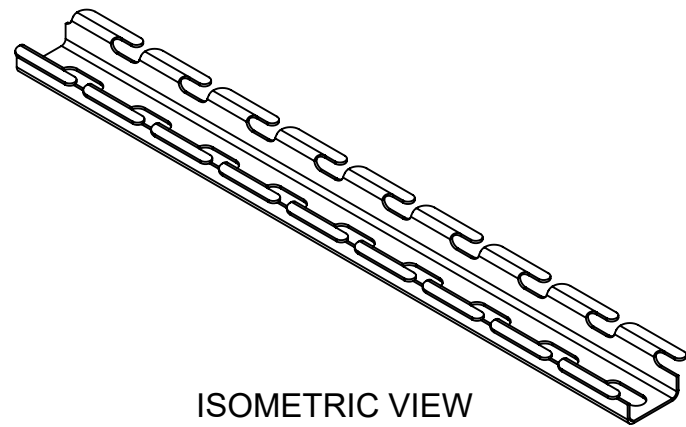

ISOMETRIC VIEW

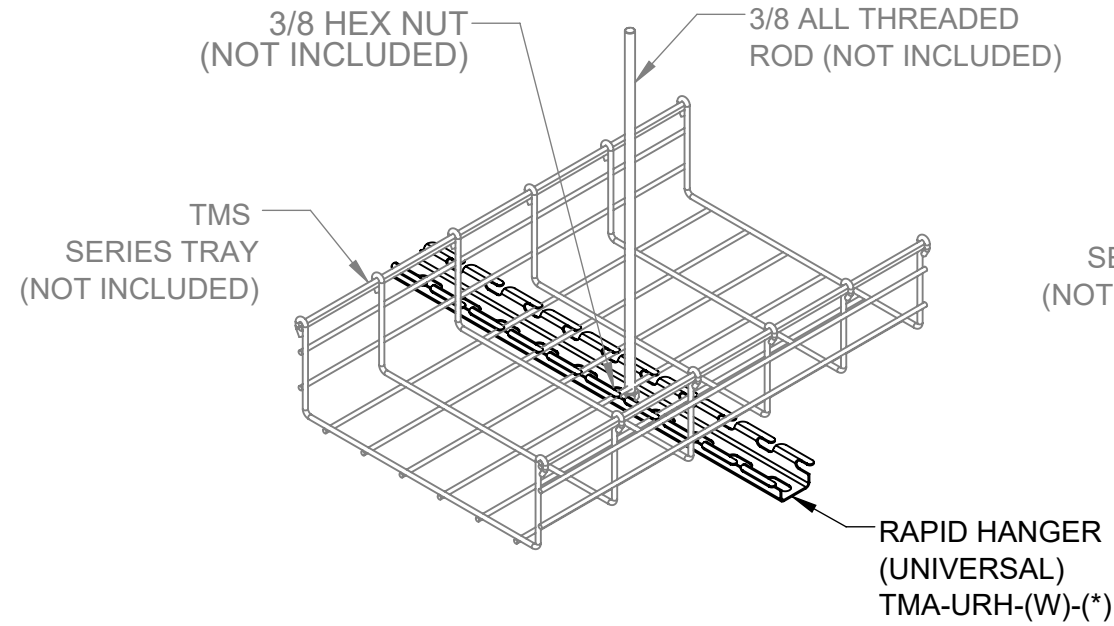

CENTER SUPPORT ASSEMBLY

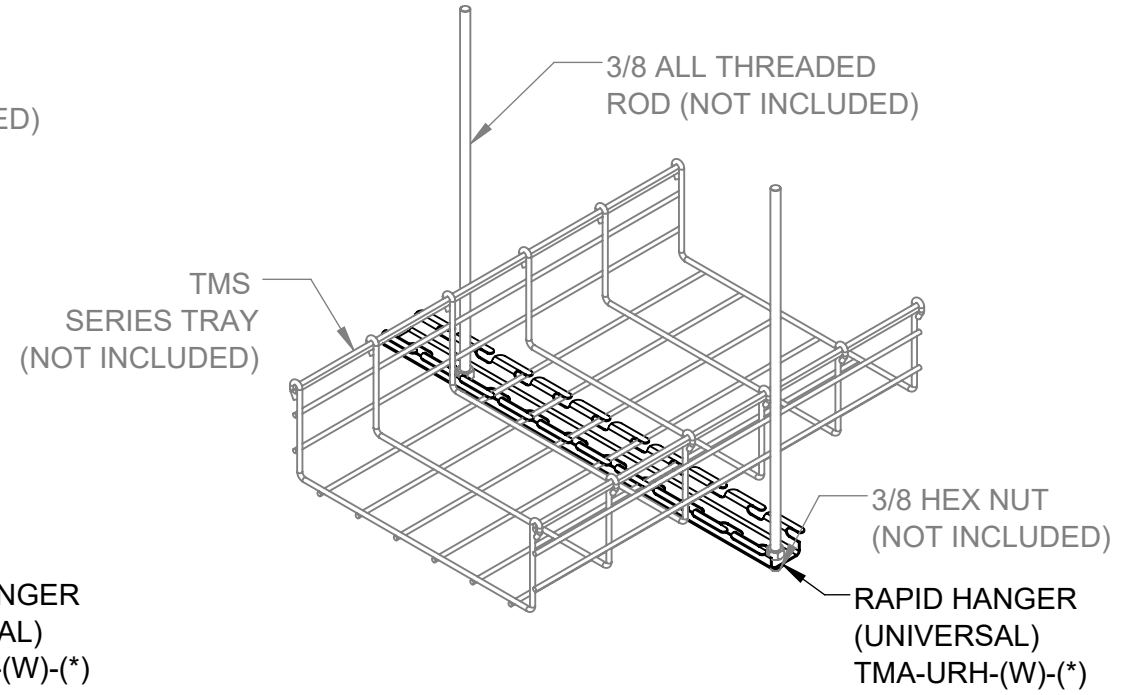

TRAPEZE SUPPORT ASSEMBLY

TMA - URH - 04 - EG

<p>SERIES TMA = TOUGHMESH ACCESSORIES</p>	<p>TYPE URH = RAPID HANGER UNIVERSAL</p>	<p>NOMINAL TRAY WIDTH (W) 04 = 4" 06 = 6" 08 = 8" 10 = 10" 12 = 12" 16 = 16" 18 = 18" 20 = 20" 24 = 24"</p>	<p>(*) MATERIAL/ FINISH EG = ELECTROPLATED ZINC PT = PAINTED HD = HOT-DIPPED GALVANIZED S4 = STAINLESS STEEL 304 S6 = STAINLESS STEEL 316</p>
--	---	--	--

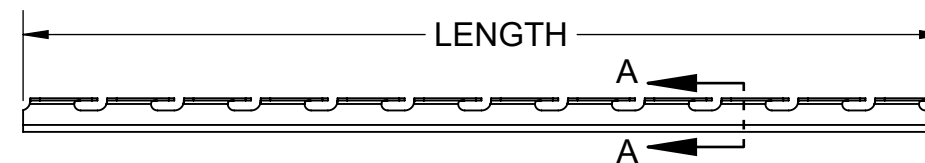

FRONT VIEW

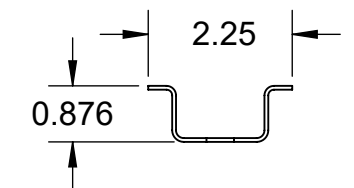

SECTION A-A

- NOTE(S):**
- 1) DIMENSIONS SHOWN ARE IN INCHES UNLESS OTHERWISE NOTED.
 - 2) ALL DIMENSIONS SHOWN ARE NOMINAL.
 - 4) SOLD PER PIECE WITHOUT HARDWARE.
 - 3) 3/8 HEX NUT AND ALL THREADED ROD TO BE ORDERED SEPARATELY.

PROPRIETARY AND CONFIDENTIAL THE INFORMATION CONTAINED IN THIS DRAWING IS THE SOLE PROPERTY OF CT INNOVATIONS. ANY REPRODUCTION IN PART OR AS A WHOLE WITHOUT THE WRITTEN PERMISSION OF CT INNOVATIONS IS PROHIBITED.			
 CT INNOVATIONS		TITLE: TOUGHMESH UNIVERSAL RAPID HANGER TMA-URH-(W)-(*)	
DRAWN BY/DATE: DL 21OCT2024	SIZE: B	DWG. NO.: CTI-S37013	REV: C
APPROVED BY/DATE: JDG	SCALE: NTS	CAD FILE NAME: CTI-S37013_A CAD SAVE DATE: Monday, October 21, 2024 3:55:21 PM	SHEET: 1 OF 1

6

5

4

3

2

1

F

F

E

E

D

D

C

C

B

B

A

A

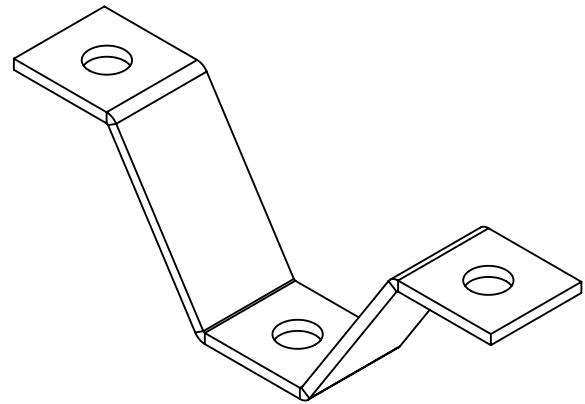

ISOMETRIC VIEW

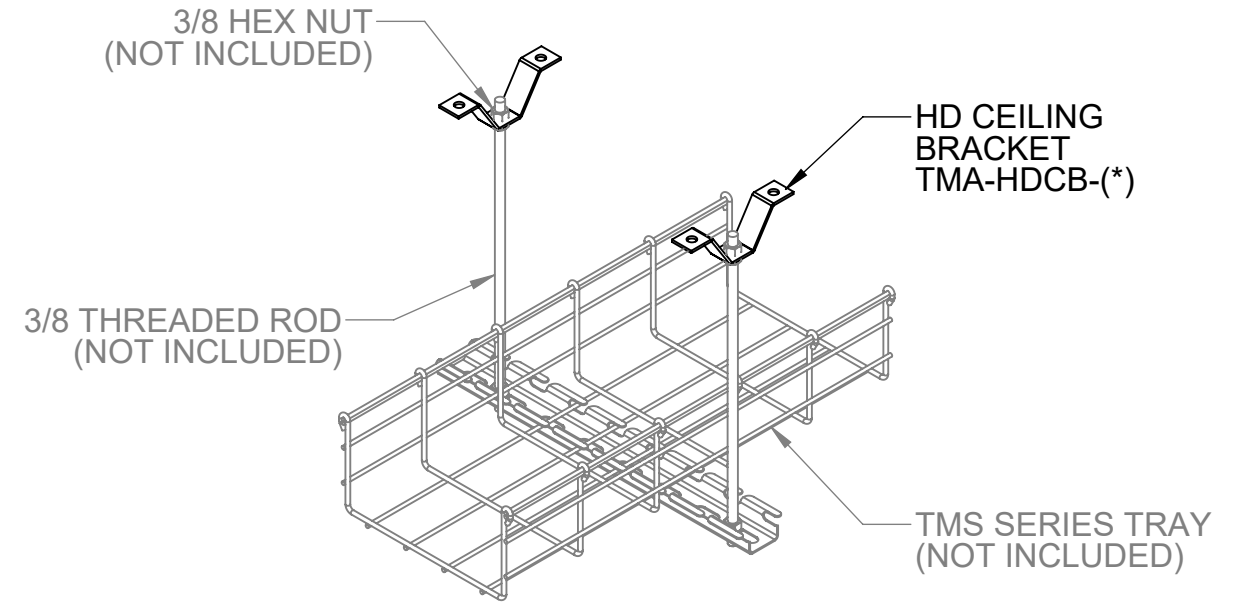

ISO INSTALLED VIEW

TMA - HDCB - EG

SERIES
TMA = TOUGHMESH
ACCESSORIES

TYPE
HDCB = HD CEILING
BRACKET

(*) MATERIAL/ FINISH
EG = ELECTROPLATED ZINC
PT = PAINTED
HD = HOT-DIPPED GALVANIZED
S4 = STAINLESS STEEL 304

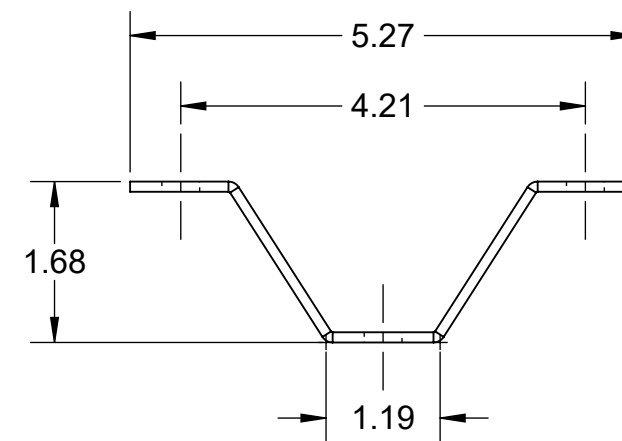

FRONT VIEW

- NOTE(S):**
- 1) DIMENSIONS SHOWN ARE IN INCHES UNLESS OTHERWISE NOTED.
 - 2) ALL DIMENSIONS SHOWN ARE NOMINAL.
 - 3) SOLD PER PIECE WITHOUT HARDWARE.
 - 4) 3/8 HEX NUT AND THREADED ROD TO BE ORDERED SEPARATELY.

PROPRIETARY AND CONFIDENTIAL THE INFORMATION CONTAINED IN THIS DRAWING IS THE SOLE PROPERTY OF CT INNOVATIONS. ANY REPRODUCTION IN PART OR AS A WHOLE WITHOUT THE WRITTEN PERMISSION OF CT INNOVATIONS IS PROHIBITED.

 CT INNOVATIONS	TITLE: HD CEILING BRACKET TMA-HDCB-(*)		
	DRAWN BY/DATE: VA 21OCT2024	SIZE: B	DWG. NO.: CTI-S37014
APPROVED BY/DATE:	SCALE: NTS	CAD FILE NAME: CTI-S37014_A CAD SAVE DATE: Monday, October 21, 2024 4:11:13 PM	SHEET: 1 OF 1

6

5

4

3

2

1

6

5

4

3

2

1

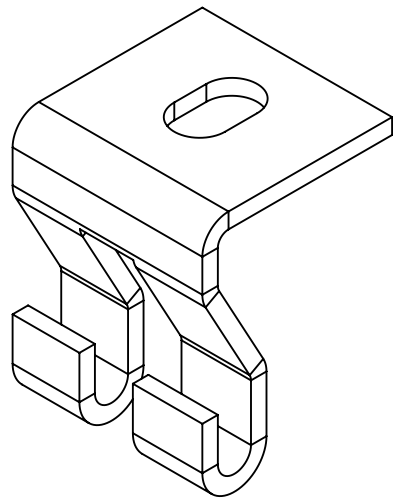

ISOMETRIC VIEW

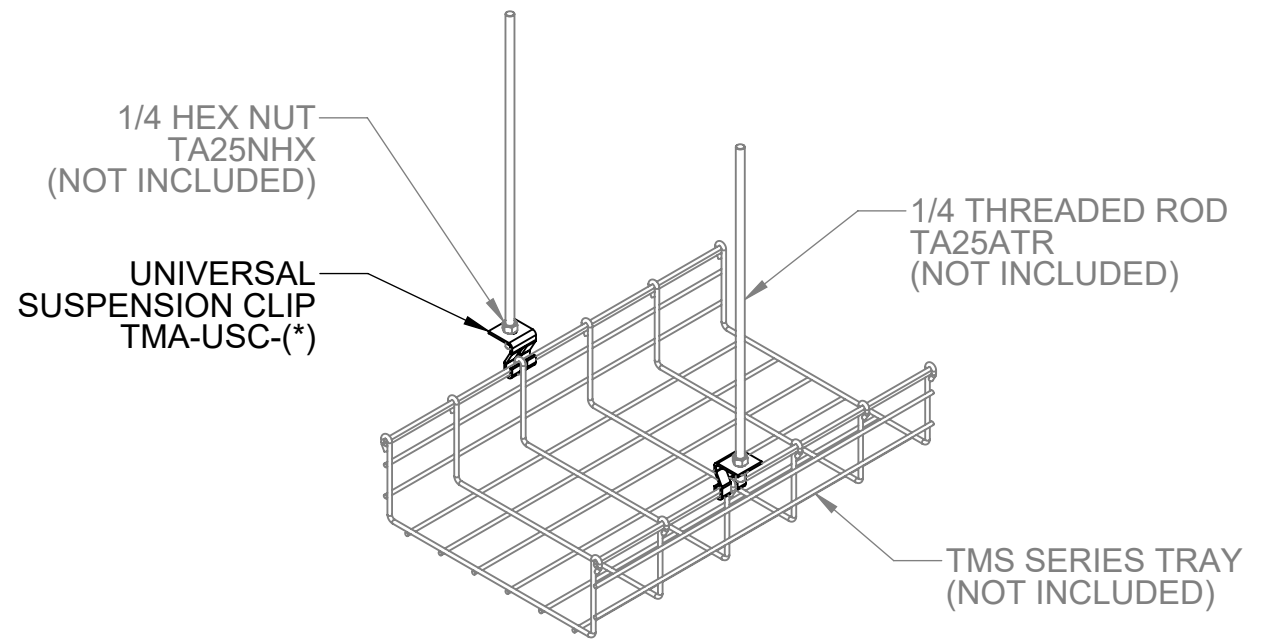

ISO INSTALLED VIEW

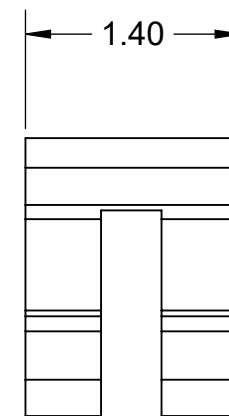
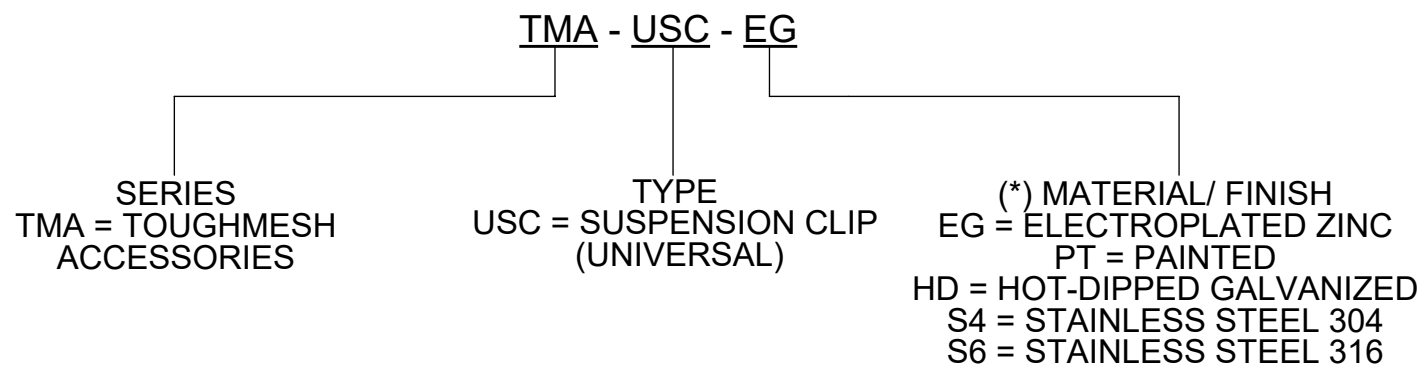

SIDE VIEW

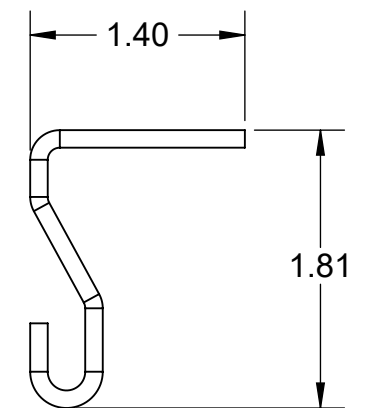

SECTION VIEW

NOTE(S):

- 1) DIMENSIONS SHOWN ARE IN INCHES UNLESS OTHERWISE NOTED.
- 2) ALL DIMENSIONS SHOWN ARE NOMINAL.
- 3) UNIVERSAL SUSPENSION CLIP IS USED FOR 2~6" HEIGHT & 2~12" WIDTH WIREBASKET TRAY.
- 4) 1/4 HARDWARE AND THREADED ROD TO BE ORDERED SEPARATELY.
- 5) SOLD IN BAG OF 10.

PROPRIETARY AND CONFIDENTIAL THE INFORMATION CONTAINED IN THIS DRAWING IS THE SOLE PROPERTY OF CT INNOVATIONS. ANY REPRODUCTION IN PART OR AS A WHOLE WITHOUT THE WRITTEN PERMISSION OF CT INNOVATIONS IS PROHIBITED.

 CT INNOVATIONS		TITLE: TOUGHMESH UNIVERSAL SUSPENSION CLIP TMA-USC-(*)	
DRAWN BY/DATE: LW 21OCT2024	SIZE: B	DWG. NO.: CTI-S37015	REV: C
APPROVED BY/DATE:	SCALE: NTS	CAD FILE NAME: TMA-USC_A CAD SAVE DATE: Monday, October 21, 2024 4:13:47 PM	SHEET: 1 OF 1

6

5

4

3

2

1

6

5

4

3

2

1

F

F

E

E

D

D

C

C

B

B

A

A

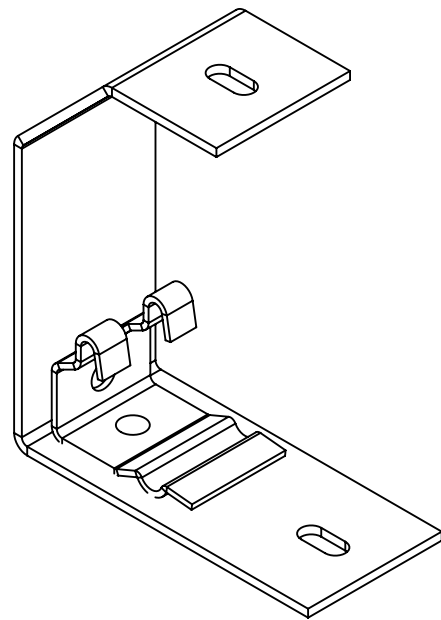

ISOMETRIC VIEW

TMA - LICH - EG

SERIES
TMA = TOUGHMESH
ACCESSORIES

TYPE
LICH = LAY-IN
CABLE HANGER

(*) MATERIAL/ FINISH
EG = ELECTROPLATED ZINC
PT = PAINTED
HD = HOT-DIPPED GALVANIZED
S4 = STAINLESS STEEL 304
S6 = STAINLESS STEEL 316

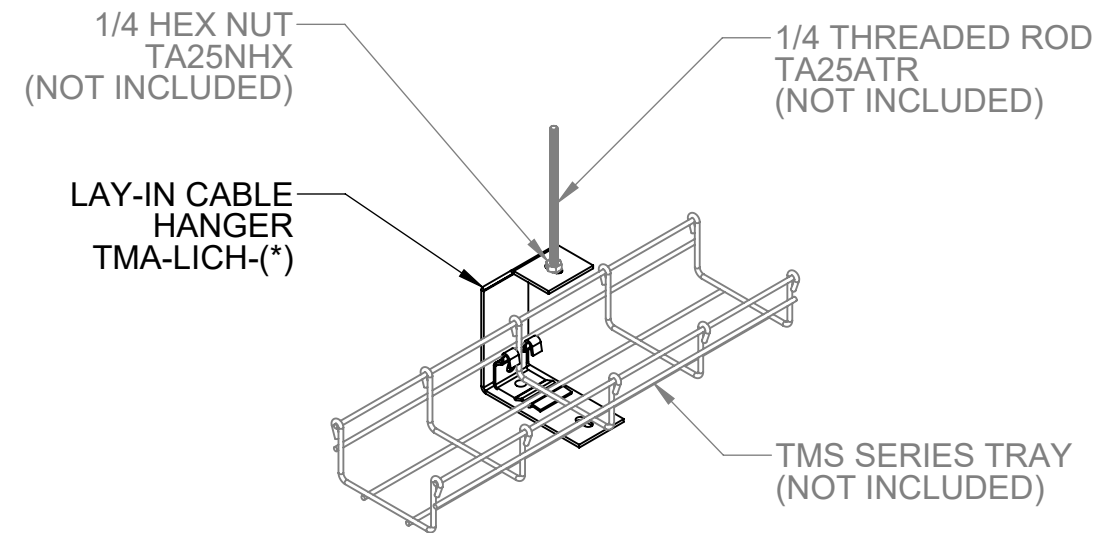

ISO INSTALLED VIEW

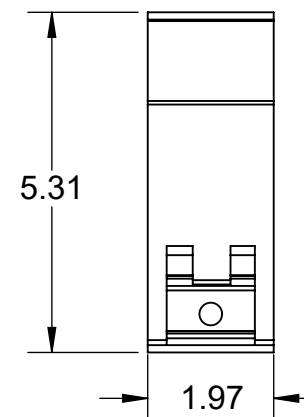

SIDE VIEW

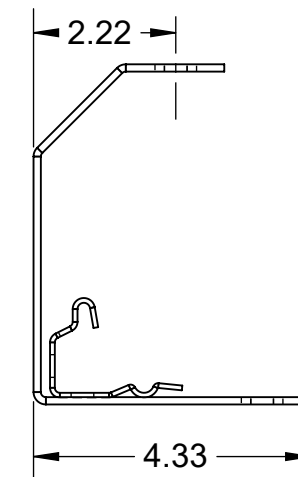

SECTION VIEW

NOTE(S):

- 1) DIMENSIONS SHOWN ARE IN INCHES UNLESS OTHERWISE NOTED.
- 2) ALL DIMENSIONS SHOWN ARE NOMINAL.
- 3) UNIVERSAL SUSPENSION CLIP IS USED FOR 2" HEIGHT & 2~6" WIDTH WIREBASKET TRAY.
- 4) SOLD PER PIECE WITHOUT HARDWARE.
- 5) 1/4 HEX NUT AND THREADED ROD TO BE ORDERED SEPARATELY.

PROPRIETARY AND CONFIDENTIAL THE INFORMATION CONTAINED IN THIS DRAWING IS THE SOLE PROPERTY OF CT INNOVATIONS. ANY REPRODUCTION IN PART OR AS A WHOLE WITHOUT THE WRITTEN PERMISSION OF CT INNOVATIONS IS PROHIBITED.

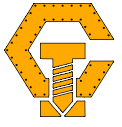
 CT INNOVATIONS	TITLE: TOUGHMESH LAY-IN CABLE HANGER TMA-LICH-(*)		
	DRAWN BY/DATE: LW 21OCT2024	SIZE: B	DWG. NO.: CTI-S37016
APPROVED BY/DATE:	SCALE: NTS	CAD FILE NAME: CTI-S37016_C CAD SAVE DATE: Monday, October 21, 2024 4:14:50 PM	SHEET: 1 OF 1

6

5

4

3

2

1

6

5

4

3

2

1

F

F

E

E

D

D

C

C

B

B

A

A

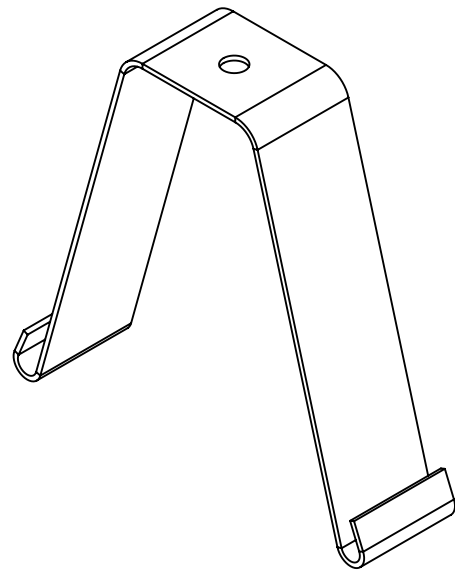

ISOMETRIC VIEW

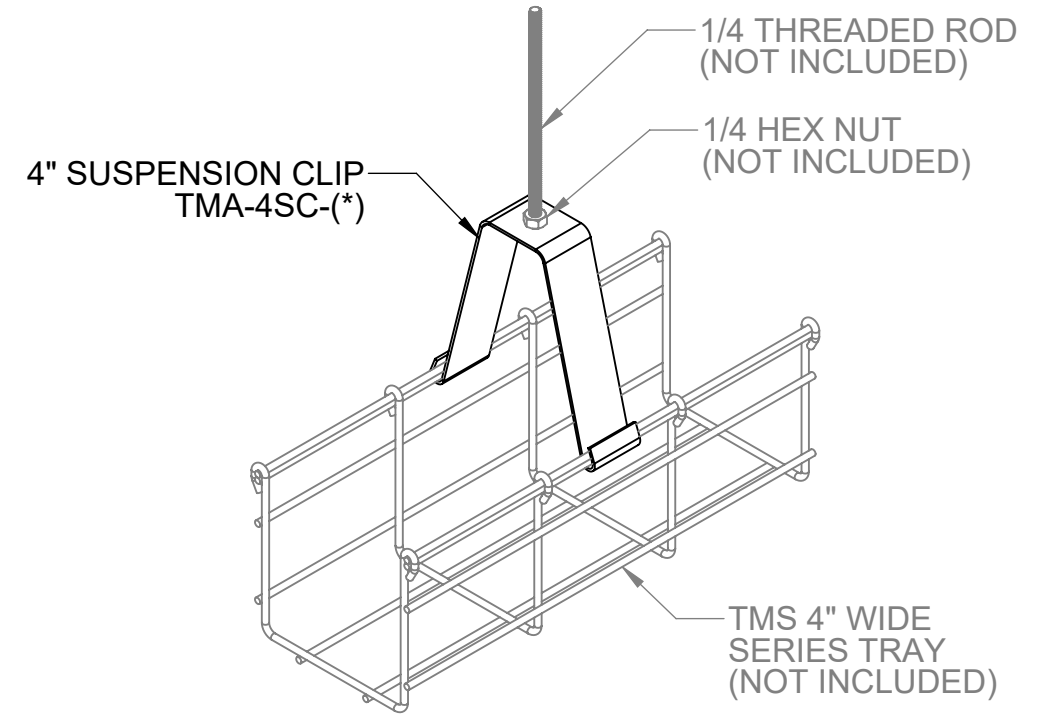

ISO INSTALLED VIEW

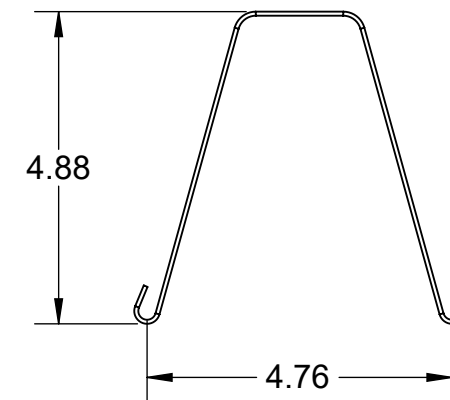
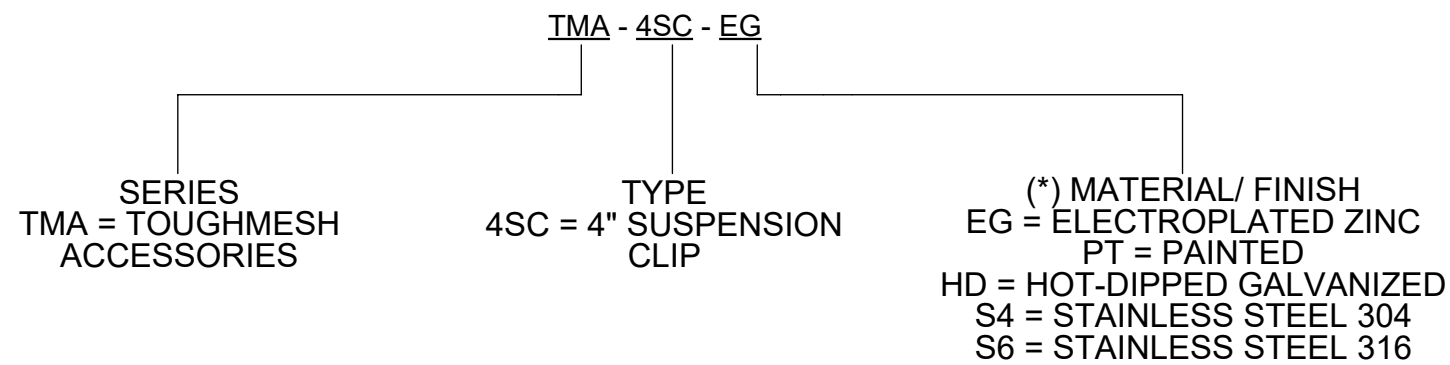

FRONT VIEW

NOTE(S):

- 1) DIMENSIONS SHOWN ARE IN INCHES UNLESS OTHERWISE NOTED.
- 2) ALL DIMENSIONS SHOWN ARE NOMINAL.
- 3) COMPATIBLE WITH 4" TRAY WIDTH ONLY.
- 4) SOLD PER PIECE.
- 5) 1/4 HEX NUT AND THREADED ROD TO BE ORDERED SEPARATELY.

PROPRIETARY AND CONFIDENTIAL THE INFORMATION CONTAINED IN THIS DRAWING IS THE SOLE PROPERTY OF CT INNOVATIONS. ANY REPRODUCTION IN PART OR AS A WHOLE WITHOUT THE WRITTEN PERMISSION OF CT INNOVATIONS IS PROHIBITED.

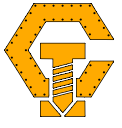
 CT INNOVATIONS	TITLE: TOUGHMESH 4" SUSPENSION CLIP TMA-4SC-(*)		
	DRAWN BY/DATE: DL 21OCT2024	SIZE: B	DWG. NO.: CTI-S37017
APPROVED BY/DATE:	SCALE: NTS	CAD FILE NAME: CTI-S37017_A CAD SAVE DATE: Monday, October 21, 2024 4:19:36 PM	SHEET: 1 OF 1

6

5

4

3

2

1

6

5

4

3

2

1

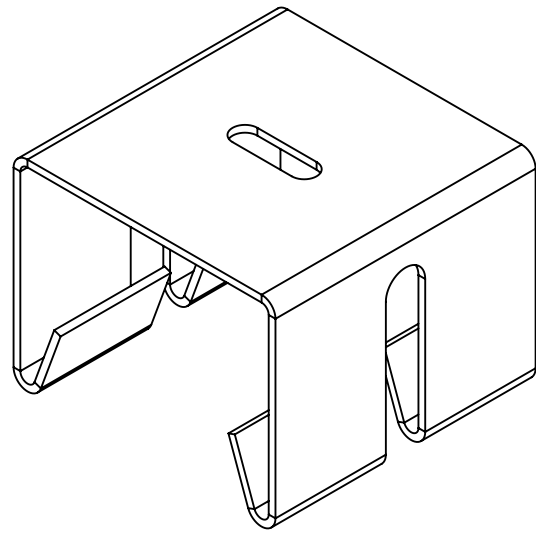

ISOMETRIC VIEW

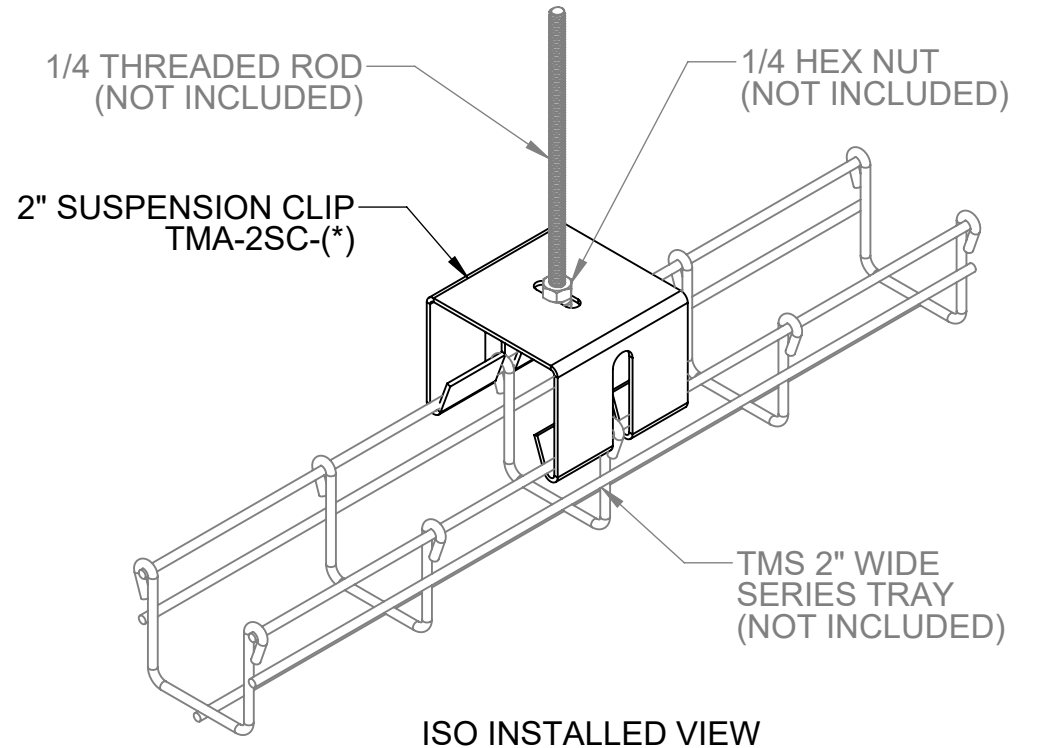

ISO INSTALLED VIEW

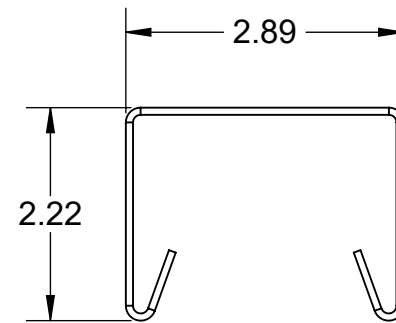
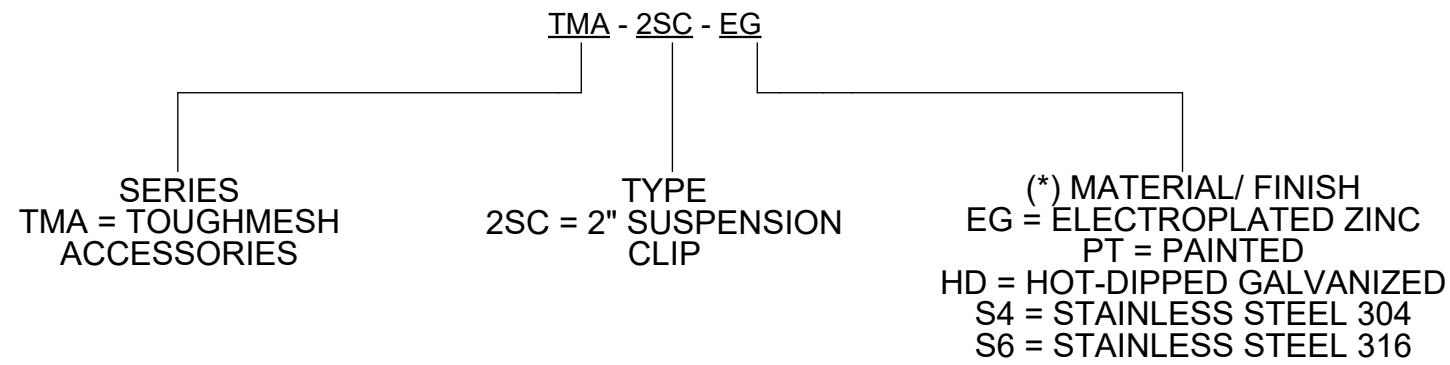

SECTION VIEW

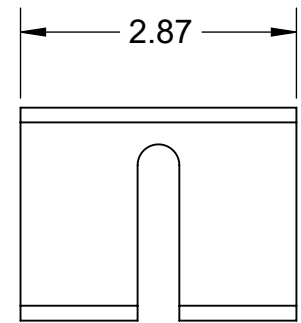

SIDE VIEW

NOTE(S):

- 1) DIMENSIONS SHOWN ARE IN INCHES UNLESS OTHERWISE NOTED.
- 2) ALL DIMENSIONS SHOWN ARE NOMINAL.
- 3) COMPATIBLE WITH 2" TRAY WIDTH ONLY.
- 4) 1/4 HEX NUT AND THREADED ROD TO BE ORDERED SEPARATELY.
- 5) SOLD IN BAG OF 10.

PROPRIETARY AND CONFIDENTIAL THE INFORMATION CONTAINED IN THIS DRAWING IS THE SOLE PROPERTY OF CT INNOVATIONS. ANY REPRODUCTION IN PART OR AS A WHOLE WITHOUT THE WRITTEN PERMISSION OF CT INNOVATIONS IS PROHIBITED.

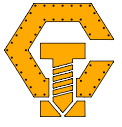
 CT INNOVATIONS	TITLE: TOUGHMESH 2" SUSPENSION CLIP TMA-2SC-(*)		
	DRAWN BY/DATE: DL 21OCT2024	SIZE: B	DWG. NO.: CTI-S37018
APPROVED BY/DATE:	SCALE: NTS	CAD FILE NAME: CTI-S37018_A CAD SAVE DATE: Monday, October 21, 2024 4:25:14 PM	SHEET: 1 OF 1

6

5

4

3

2

1

6

5

4

3

2

1

TABLE 1

TRAY WIDTH (in)	HOLD DOWN KIT QTY TMA-HDKIT-(*))	LENGTH (in)
4	1	5.12
6	2	7.09
8	2	9.06
10	2	11.02
12	2	12.99
16	2	16.93
20	2	20.87
24	2	24.80

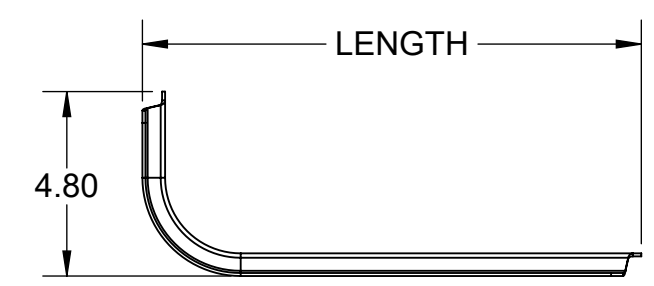
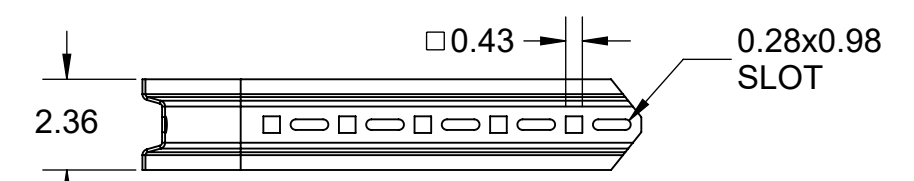
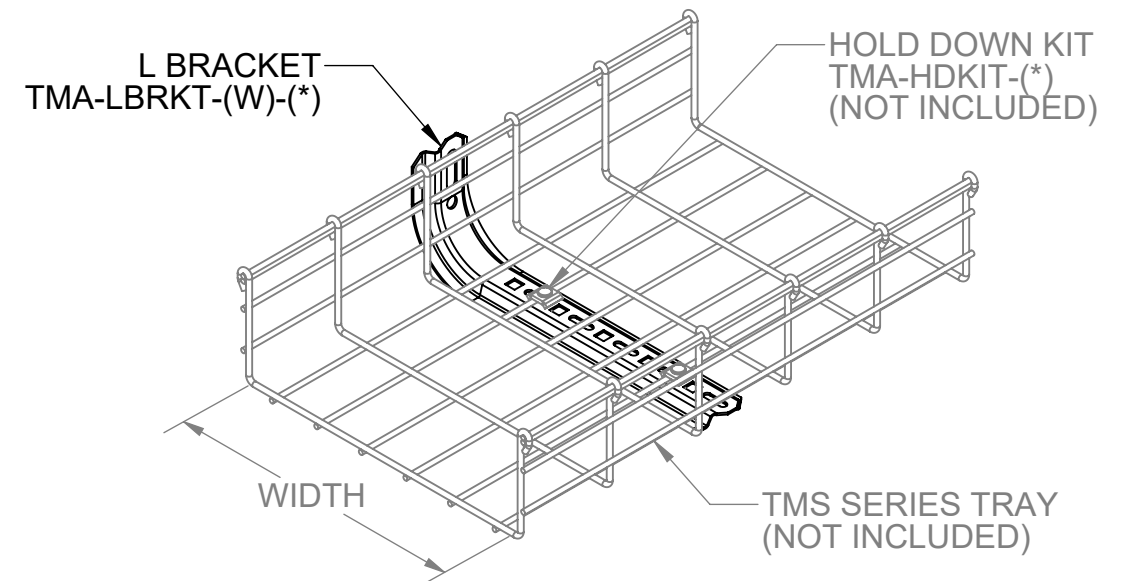
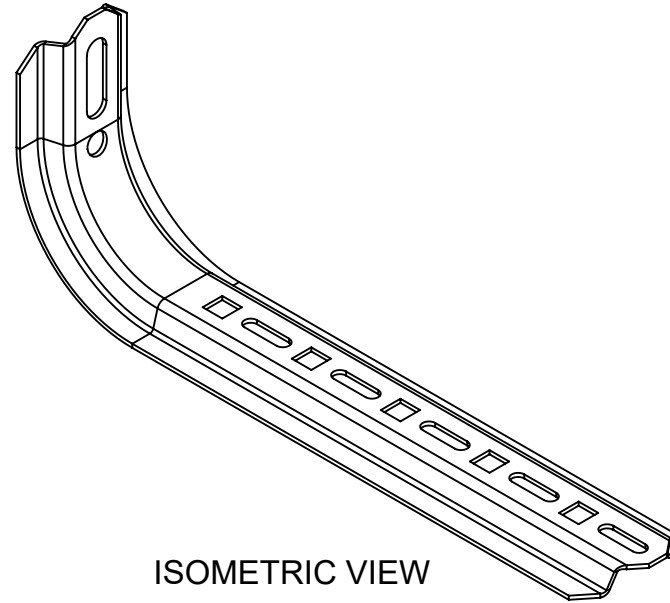

TMA - LBRKT - 12 - EG

SERIES TMA = TOUGHMESH ACCESSORIES

TYPE LBRKT = L BRACKET

(W) NOMINAL WIDTH
 04 = 4"
 06 = 6"
 08 = 8"
 10 = 10"
 12 = 12"
 16 = 16"
 20 = 20"
 24 = 24"

(*)) MATERIAL/ FINISH
 EG = ELECTROPLATED ZINC
 PT = PAINTED
 HD = HOT-DIPPED GALVANIZED
 S4 = STAINLESS STEEL 304
 S6 = STAINLESS STEEL 316

NOTE(S):

1) DIMENSIONS SHOWN ARE IN INCHES UNLESS OTHERWISE NOTED.

2) ALL DIMENSIONS SHOWN ARE NOMINAL.

3) SOLD PER PIECE WITHOUT HARDWARE.

4) HOLD DOWN KIT "TMA-HDKIT-(*))" TO BE ORDERED SEPARATELY. REFER TO TABLE 1 FOR THE REQUIRED QUANTITY.

PROPRIETARY AND CONFIDENTIAL THE INFORMATION CONTAINED IN THIS DRAWING IS THE SOLE PROPERTY OF CT INNOVATIONS. ANY REPRODUCTION IN PART OR AS A WHOLE WITHOUT THE WRITTEN PERMISSION OF CT INNOVATIONS IS PROHIBITED.



TOUGHMESH L BRACKET TMA-LBRKT-(W)-(*))

DRAWN BY/DATE: DL 21OCT2024	SIZE: B	DWG. NO.: CTI-S37019	REV: C
APPROVED BY/DATE:	SCALE: NTS	CAD FILE NAME: CTI-S37019_C CAD SAVE DATE: Monday, October 21, 2024 4:27:10 PM	SHEET: 1 OF 1

6

5

4

3

2

1

6

5

4

3

2

1

F

F

E

E

D

D

C

C

B

B

A

A

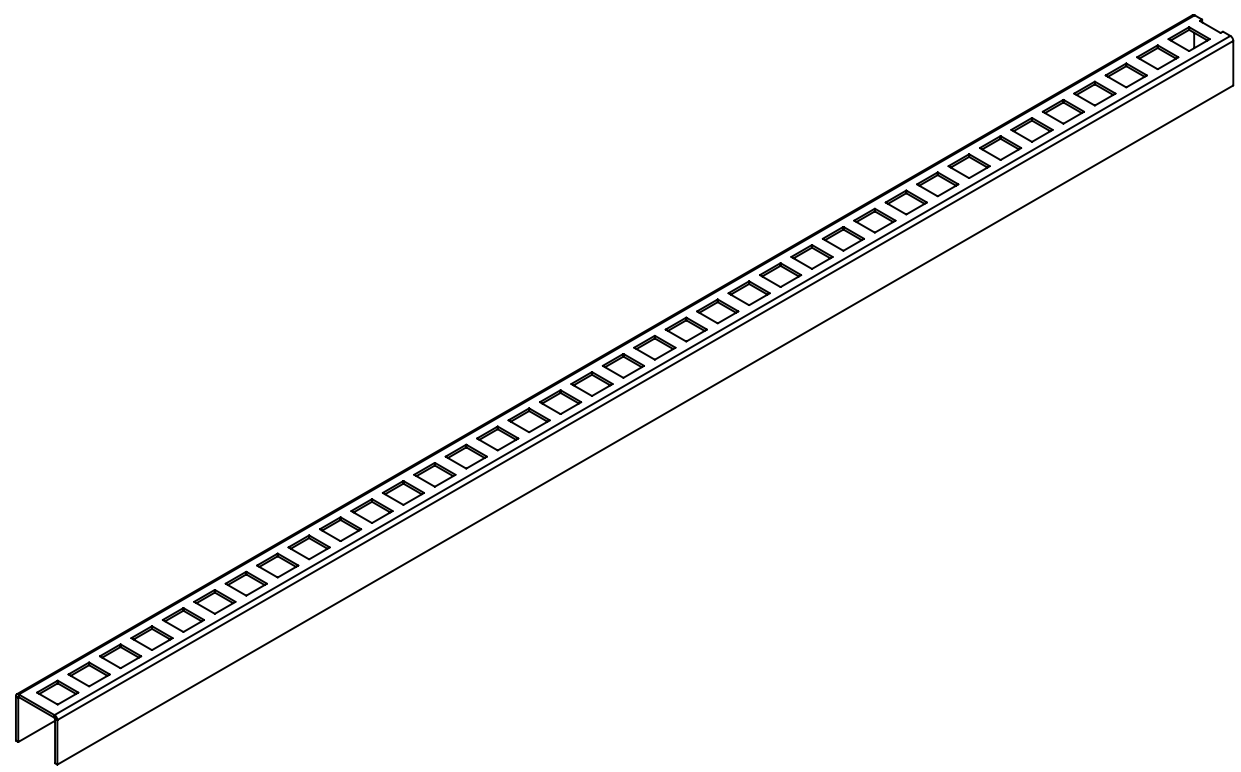

ISOMETRIC VIEW

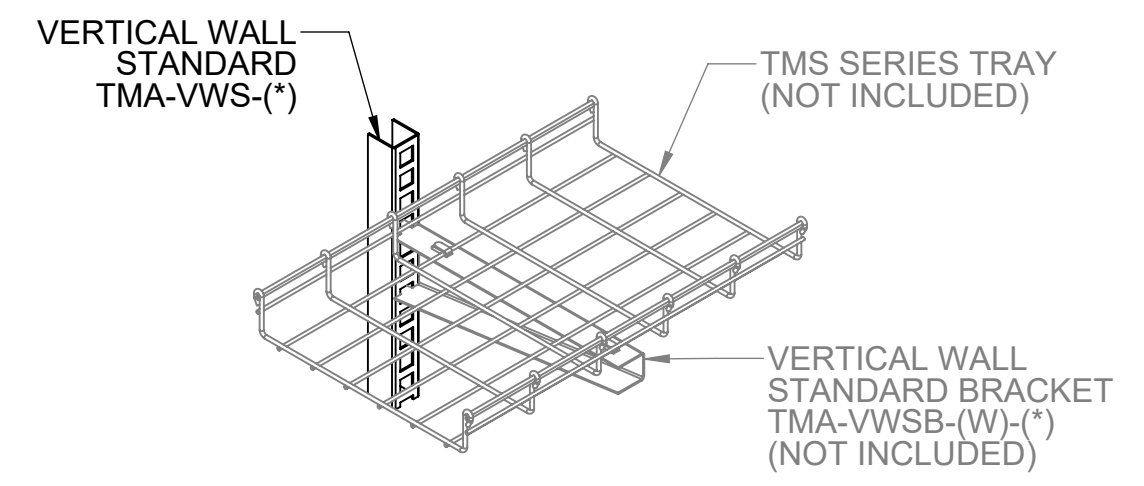

ISO INSTALLED VIEW

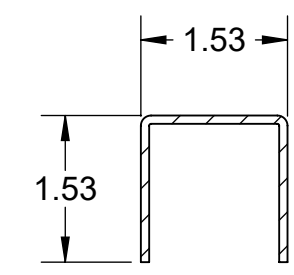

SECTION A-A

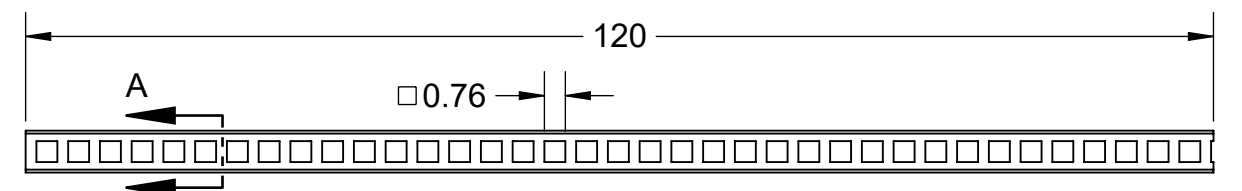

TOP VIEW

TMA - VWS - EG

SERIES
TMA = TOUGHMESH ACCESSORIES

TYPE
VWSB = VERTICAL WALL STANDARD

(*) MATERIAL/ FINISH
EG = ELECTROPLATED ZINC
PT = PAINTED
HD = HOT-DIPPED GALVANIZED
S4 = STAINLESS STEEL 304
S6 = STAINLESS STEEL 316

NOTE(S):
 1) DIMENSIONS SHOWN ARE IN INCHES UNLESS OTHERWISE NOTED.
 2) ALL DIMENSIONS SHOWN ARE NOMINAL.
 3) SOLD PER PIECE.

PROPRIETARY AND CONFIDENTIAL THE INFORMATION CONTAINED IN THIS DRAWING IS THE SOLE PROPERTY OF CT INNOVATIONS. ANY REPRODUCTION IN PART OR AS A WHOLE WITHOUT THE WRITTEN PERMISSION OF CT INNOVATIONS IS PROHIBITED.

	TITLE: TOUGHMESH VERTICAL WALL STANDARD TMA-VWS-(*)		
	DRAWN BY/DATE: DL 21OCT2024	SIZE: B	DWG. NO.: CTI-S37021
APPROVED BY/DATE:	SCALE: NTS	CAD FILE NAME: TMA-VWSB_A CAD SAVE DATE: Monday, October 21, 2024 4:28:46 PM	SHEET: 1 OF 1

6

5

4

3

2

1

TRAY WIDTH (in)	LENGTH (in)
4	5.82
6	7.82
8	9.82
10	11.82
12	13.82
16	17.82
20	21.82
24	25.82

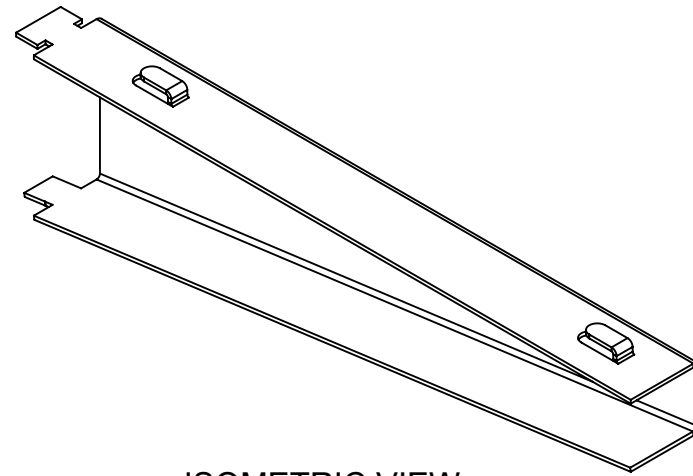

ISOMETRIC VIEW

VERTICAL WALL STANDARD TMA-VWS-(*)(NOT INCLUDED)

TMS SERIES TRAY (NOT INCLUDED)

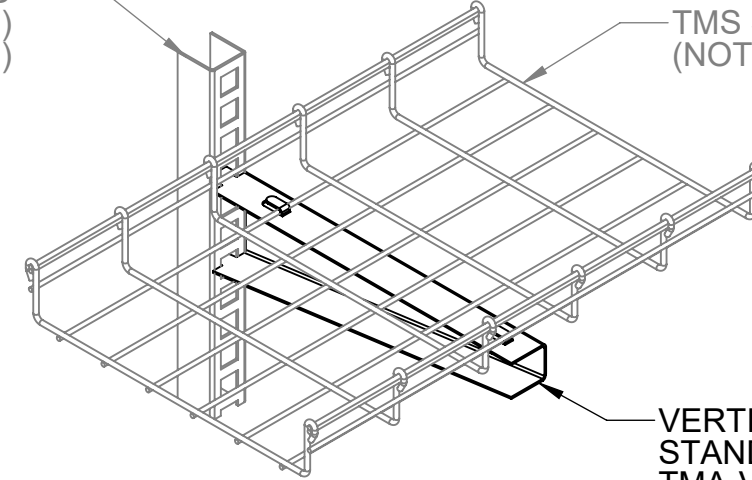

VERTICAL WALL STANDARD BRACKET TMA-VWSB-(W)-(*)

ISO INSTALLED VIEW

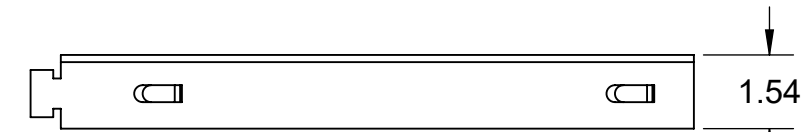

TOP VIEW

1.54

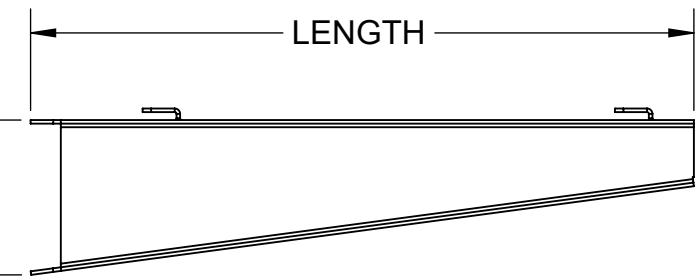

SIDE VIEW

3.23

LENGTH

TMA - VWSB - 12 - EG

SERIES: TMA = TOUGHMESH ACCESSORIES
 TYPE: VWSB = VERTICAL WALL STANDARD BRACKET
 (W) NOMINAL WIDTH:
 04 = 4"
 06 = 6"
 08 = 8"
 10 = 10"
 12 = 12"
 16 = 16"
 20 = 20"
 24 = 24"

(*) MATERIAL/ FINISH:
 EG = ELECTROPLATED ZINC
 PT = PAINTED
 HD = HOT-DIPPED GALVANIZED
 S4 = STAINLESS STEEL 304
 S6 = STAINLESS STEEL 316

NOTE(S):

- 1) DIMENSIONS SHOWN ARE IN INCHES UNLESS OTHERWISE NOTED.
- 2) ALL DIMENSIONS SHOWN ARE NOMINAL.
- 3) SOLD PER PIECE.

PROPRIETARY AND CONFIDENTIAL THE INFORMATION CONTAINED IN THIS DRAWING IS THE SOLE PROPERTY OF CT INNOVATIONS. ANY REPRODUCTION IN PART OR AS A WHOLE WITHOUT THE WRITTEN PERMISSION OF CT INNOVATIONS IS PROHIBITED.

	TITLE: VERTICAL WALL STANDARD BRACKET TMA-VWSB-(W)-(*)			
	DRAWN BY/DATE: DL 21OCT2024	SIZE: B	DWG. NO.: CTI-S37022	REV: C
	APPROVED BY/DATE:	SCALE: NTS	CAD FILE NAME: CTI-S37022_A CAD SAVE DATE: Monday, October 21, 2024 4:29:42 PM	SHEET: 1 OF 1

TRAY WIDTH (in)	LENGTH (in)
4	10
6	12
8	14
10	16
12	18
16	22
20	26
24	30

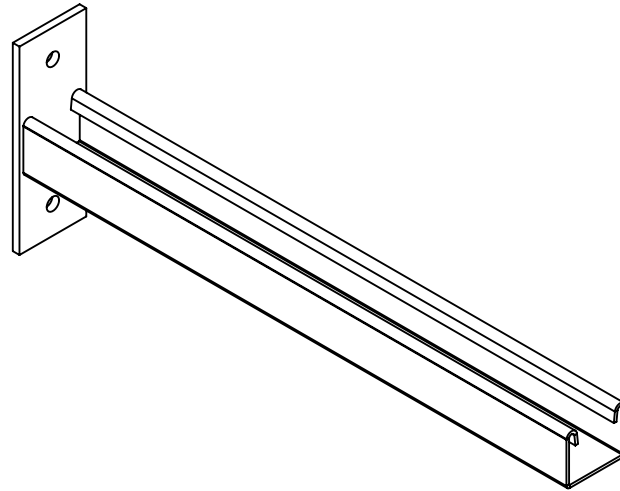

ISOMETRIC VIEW

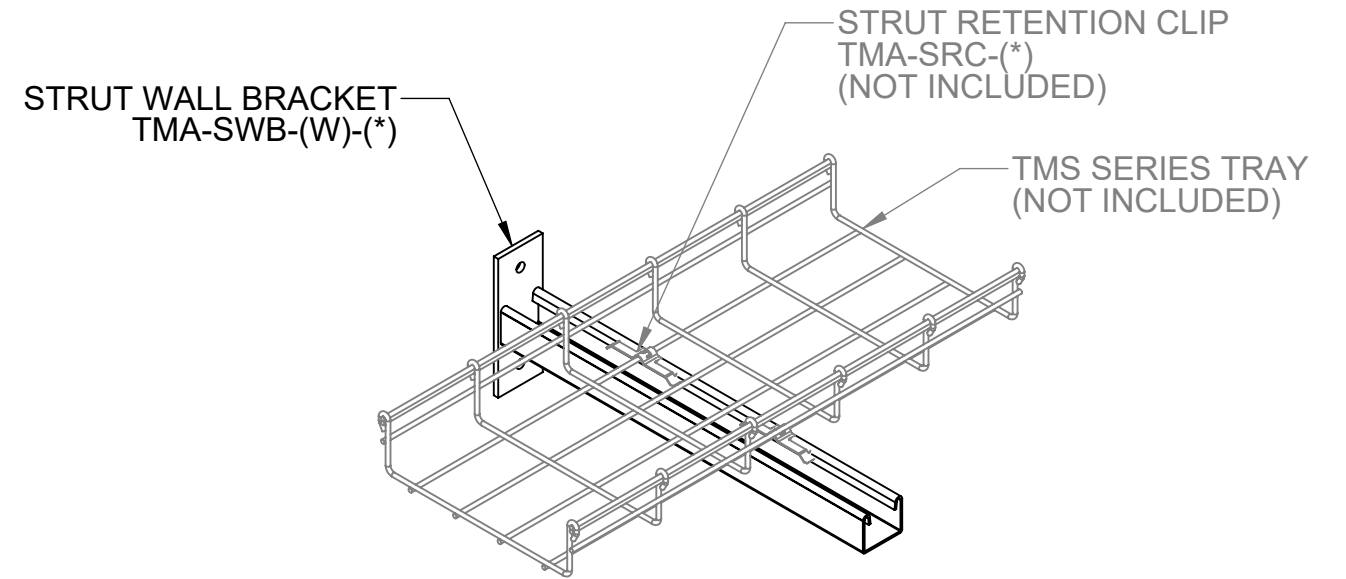

ISO INSTALLED VIEW

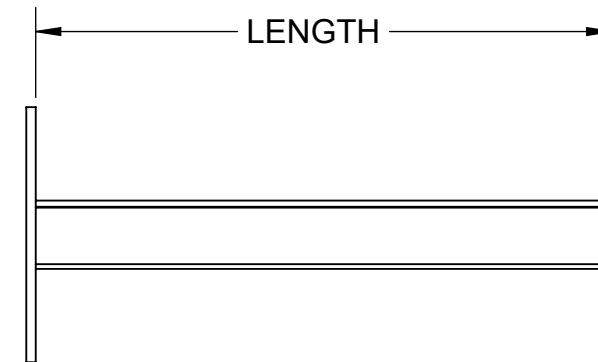
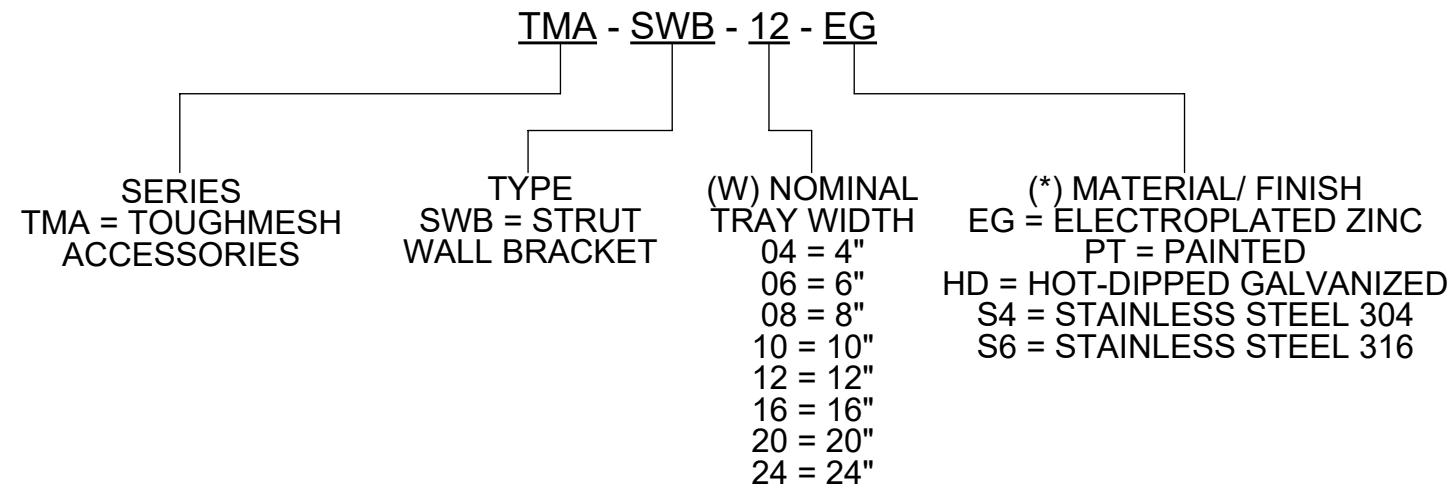

SIDE VIEW

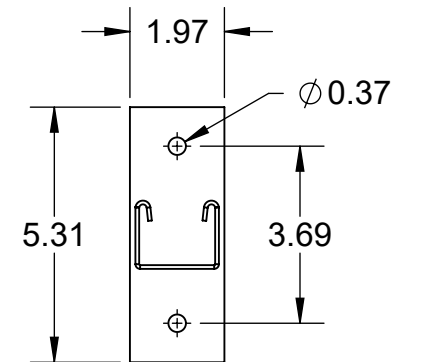

FRONT VIEW

NOTE(S):

- 1) DIMENSIONS SHOWN ARE IN INCHES UNLESS OTHERWISE NOTED.
- 2) ALL DIMENSIONS SHOWN ARE NOMINAL.
- 3) SOLD PER PIECE.

PROPRIETARY AND CONFIDENTIAL THE INFORMATION CONTAINED IN THIS DRAWING IS THE SOLE PROPERTY OF CT INNOVATIONS. ANY REPRODUCTION IN PART OR AS A WHOLE WITHOUT THE WRITTEN PERMISSION OF CT INNOVATIONS IS PROHIBITED.

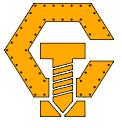
 CT INNOVATIONS	TITLE: TOUGHMESH STRUT WALL BRACKET TMA-SWB-(W)-(*)			
	DRAWN BY/DATE: DL 21OCT2024	SIZE: B	DWG. NO.: CTI-S37024	REV: C
	APPROVED BY/DATE:	SCALE: NTS	CAD FILE NAME: CTI-S37024_A CAD SAVE DATE: Monday, October 21, 2024 4:31:23 PM	SHEET: 1 OF 1

6

5

4

3

2

1

F

F

E

E

D

D

C

C

B

B

A

A

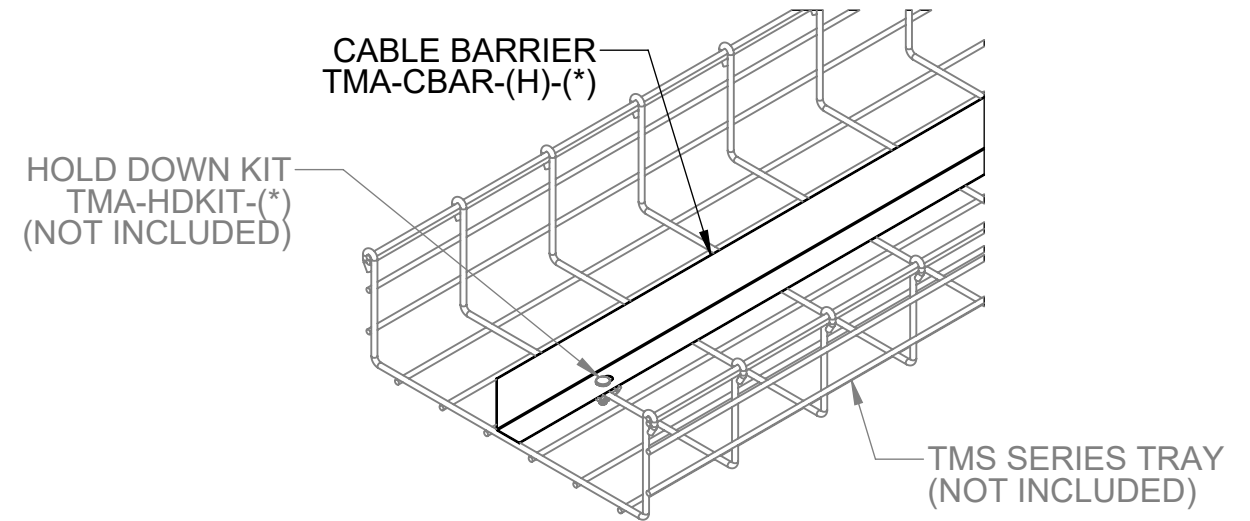
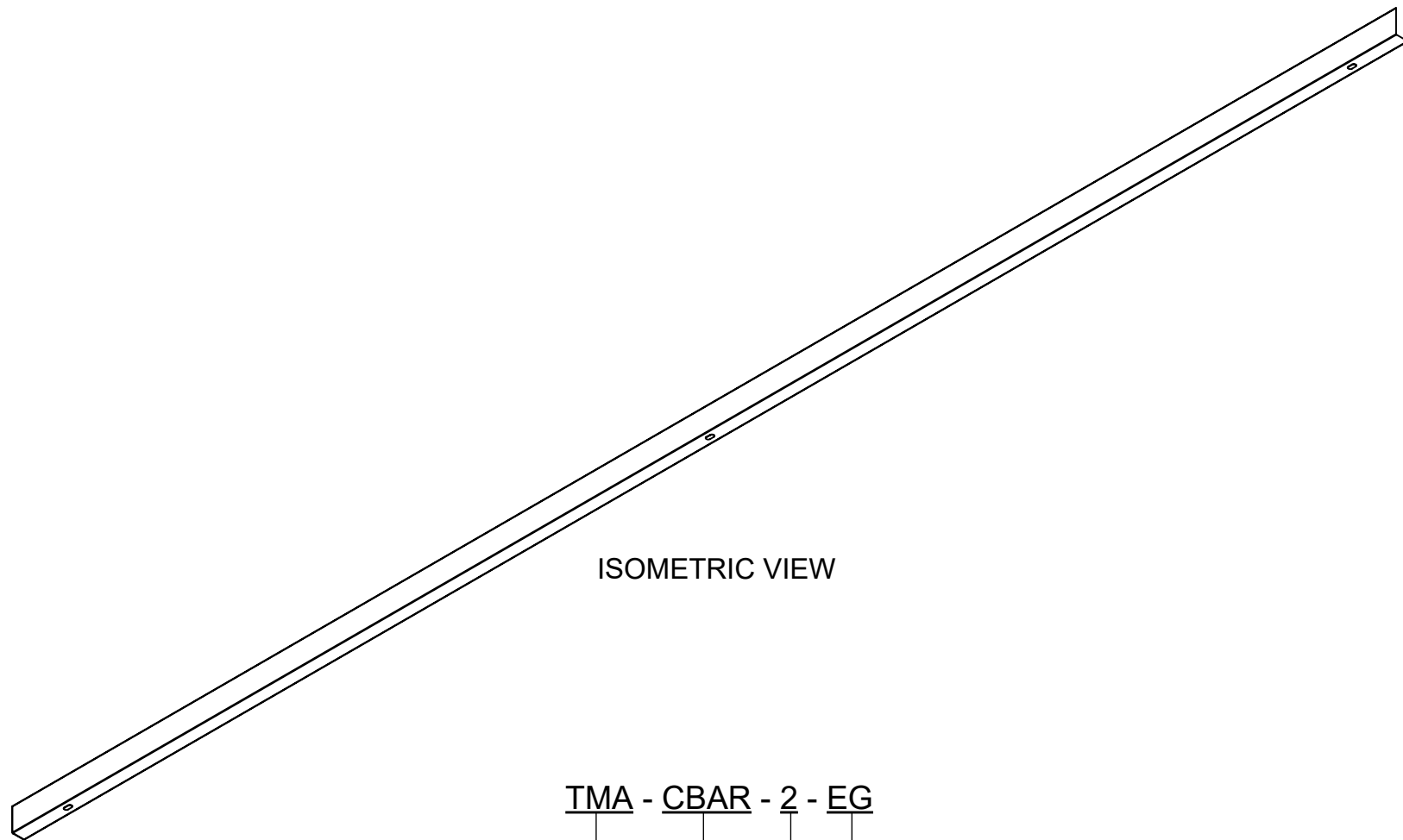

TMA - CBAR - 2 - EG

SERIES
TMA = TOUGHMESH ACCESSORIES

TYPE
CBAR = CABLE BARRIER

(H) NOMINAL HEIGHT
2 = 2"
4 = 4"
6 = 6"

(*) MATERIAL/ FINISH
EG = ELECTROPLATED ZINC
PT = PAINTED
HD = HOT-DIPPED GALVANIZED
S4 = STAINLESS STEEL 304
S6 = STAINLESS STEEL 316

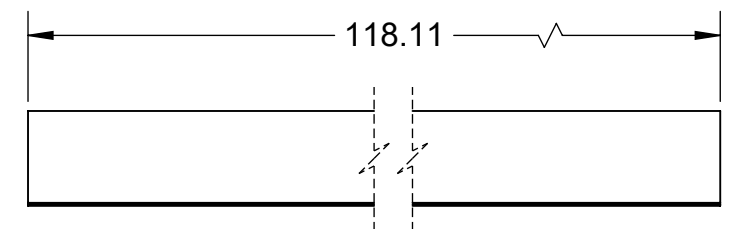
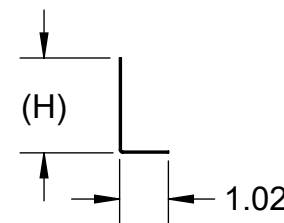

NOTE(S):

- 1) DIMENSIONS SHOWN ARE IN INCHES UNLESS OTHERWISE NOTED.
- 2) ALL DIMENSIONS SHOWN ARE NOMINAL.
- 3) CABLE BARRIER IS USED FOR 2~6" HEIGHT & 2~24" WIDTH WIREBASKET TRAY.
- 4) SOLD PER PIECE.
- 5) THREE PIECES HOLD DOWN KIT "TMA-HDKIT-(*)" TO BE ORDERED SEPARATELY.

PROPRIETARY AND CONFIDENTIAL THE INFORMATION CONTAINED IN THIS DRAWING IS THE SOLE PROPERTY OF CT INNOVATIONS. ANY REPRODUCTION IN PART OR AS A WHOLE WITHOUT THE WRITTEN PERMISSION OF CT INNOVATIONS IS PROHIBITED.

	TITLE: TOUGHMESH CABLE BARRIER TMA-CBAR-(H)-(*)		
	DRAWN BY/DATE: LW 21OCT2024	SIZE: B	DWG. NO.: CTI-S37025
APPROVED BY/DATE:	SCALE: NTS	CAD FILE NAME: TMA-CBAR-(H)_A CAD SAVE DATE: Monday, October 21, 2024 4:54:18 PM	SHEET: 1 OF 1

6

5

4

3

2

1

6

5

4

3

2

1

F

F

E

E

D

D

C

C

B

B

A

A

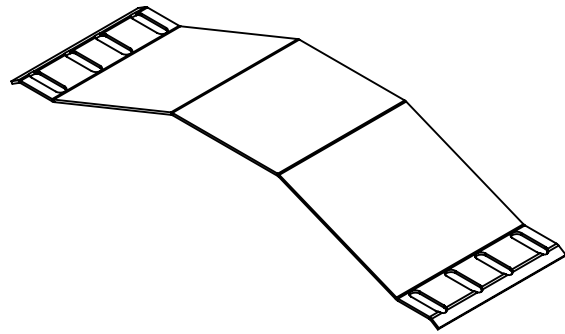

ISOMETRIC VIEW

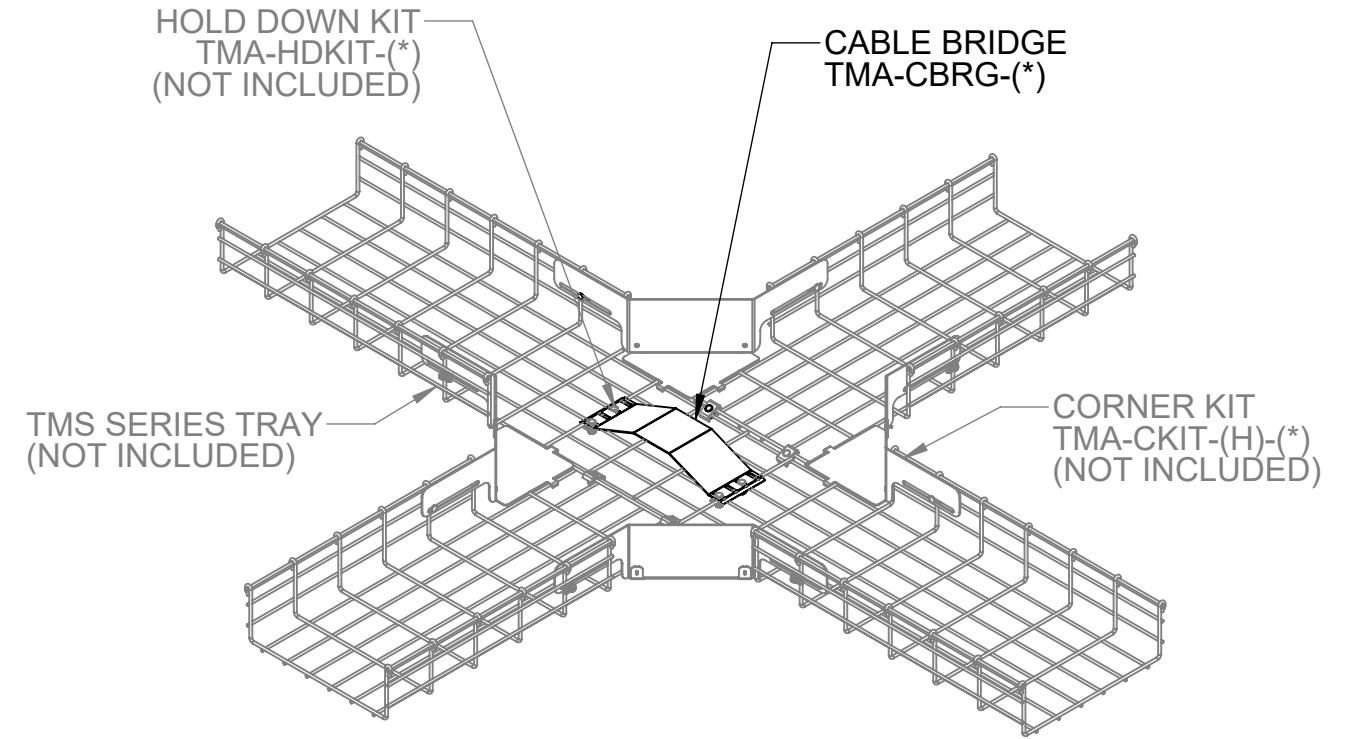

ISO INSTALLED VIEW

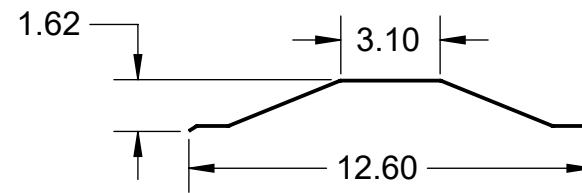
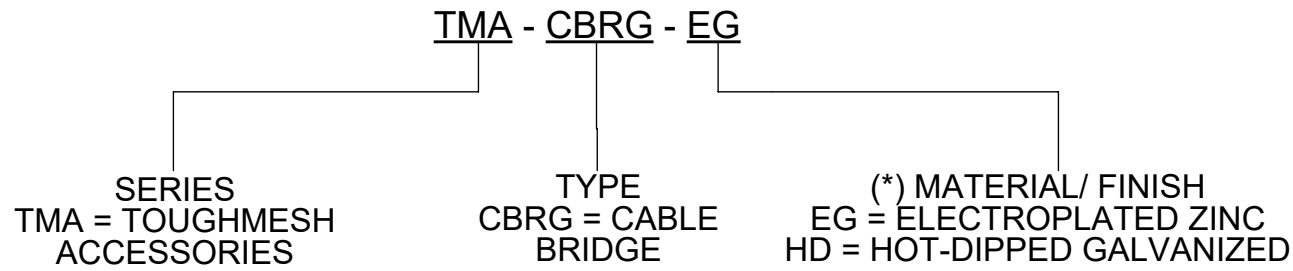

SECTION VIEW

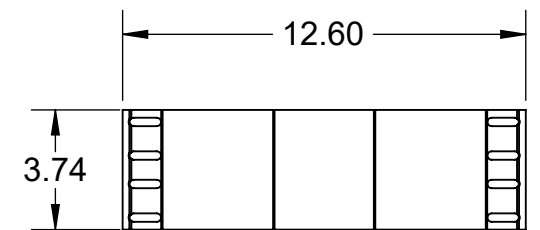

TOP VIEW

NOTE(S):

- 1) DIMENSIONS SHOWN ARE IN INCHES UNLESS OTHERWISE NOTED.
- 2) ALL DIMENSIONS SHOWN ARE NOMINAL.
- 3) SOLD PER PIECE.
- 4) FOUR (4) PIECES HOLD DOWN KIT "TMA-HDKIT-(*)" TO BE ORDERED SEPARATELY.

PROPRIETARY AND CONFIDENTIAL THE INFORMATION CONTAINED IN THIS DRAWING IS THE SOLE PROPERTY OF CT INNOVATIONS. ANY REPRODUCTION IN PART OR AS A WHOLE WITHOUT THE WRITTEN PERMISSION OF CT INNOVATIONS IS PROHIBITED.

 CT INNOVATIONS	TITLE: TOUGHMESH CABLE BRIDGE TMA-CBRG-(*)		
	DRAWN BY/DATE: DL 21OCT2024	SIZE: B	DWG. NO.: CTI-S37026
APPROVED BY/DATE:	SCALE: NTS	CAD FILE NAME: TMA-CBRG_A CAD SAVE DATE: Monday, October 21, 2024 5:00:45 PM	SHEET: 1 OF 1

6

5

4

3

2

1

6

5

4

3

2

1

F

F

E

E

D

D

C

C

B

B

A

A

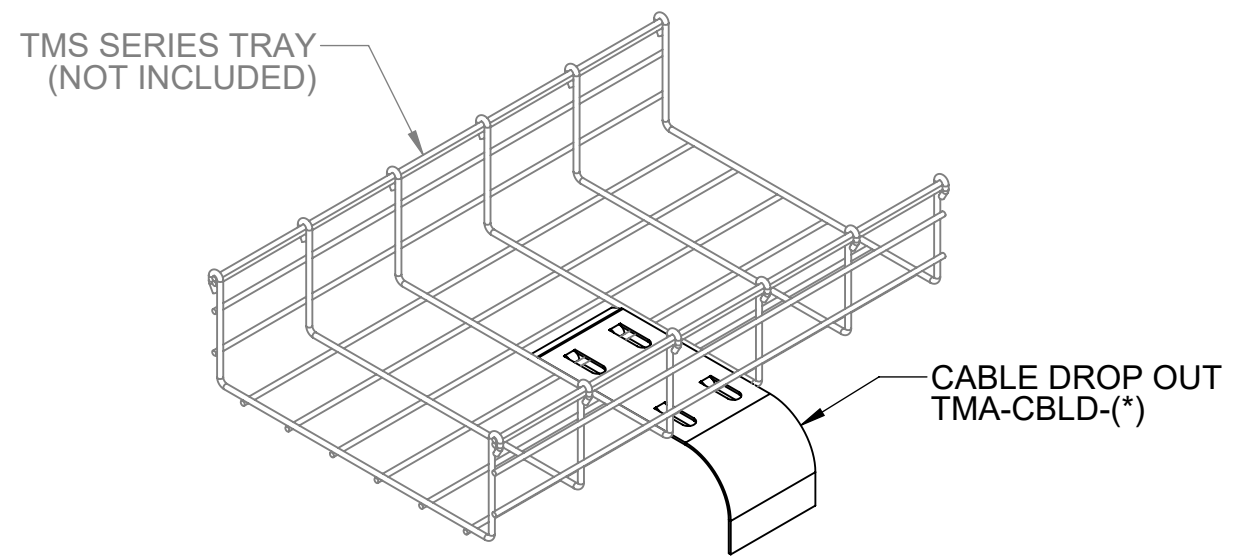
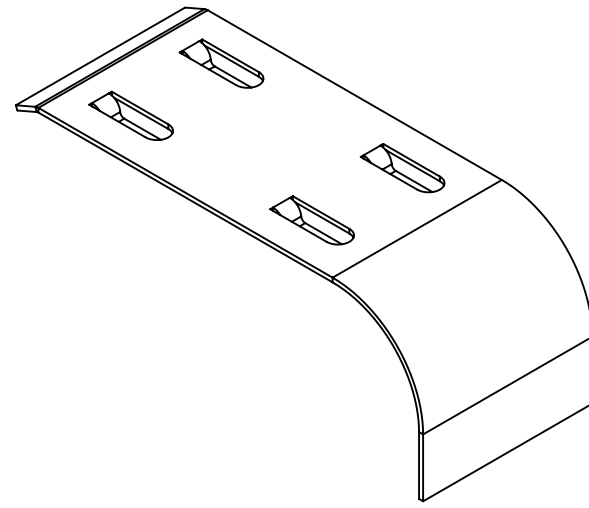

TMA - CBLD - EG

SERIES
TMA = TOUGHMESH ACCESSORIES

TYPE
CBLD = CABLE DROP OUT

(*) MATERIAL/ FINISH
EG = ELECTROPLATED ZINC
PT = PAINTED
HD = HOT-DIPPED GALVANIZED
S4 = STAINLESS STEEL 304
S6 = STAINLESS STEEL 316

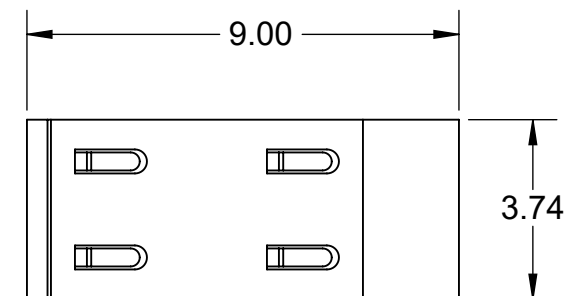
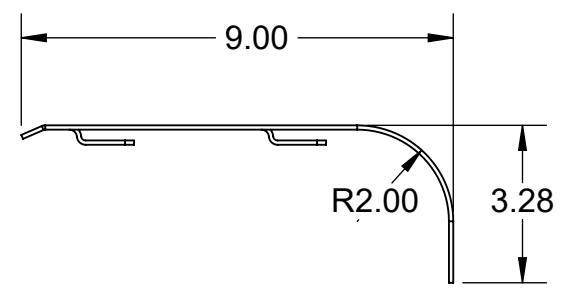

NOTE(S):

- 1) DIMENSIONS SHOWN ARE IN INCHES UNLESS OTHERWISE NOTED.
- 2) ALL DIMENSIONS SHOWN ARE NOMINAL.
- 3) CABLE DROP OUT IS USED FOR 2~6" HEIGHT & 4~24" WIDTH WIREBASKET TRAY.
- 4) SOLD PER PIECE.

PROPRIETARY AND CONFIDENTIAL THE INFORMATION CONTAINED IN THIS DRAWING IS THE SOLE PROPERTY OF CT INNOVATIONS. ANY REPRODUCTION IN PART OR AS A WHOLE WITHOUT THE WRITTEN PERMISSION OF CT INNOVATIONS IS PROHIBITED.

	TITLE: TOUGHMESH CABLE DROP OUT TMA-CBLD-(*)			
	DRAWN BY/DATE: DL 21OCT2024	SIZE: B	DWG. NO.: CTI-S37027	REV: C
APPROVED BY/DATE:	SCALE: NTS	CAD FILE NAME: TMA-CBLD_A CAD SAVE DATE: Monday, October 21, 2024 5:14:13 PM	SHEET: 1 OF 1	

6

5

4

3

2

1

6

5

4

3

2

1

F

F

E

E

D

D

C

C

B

B

A

A

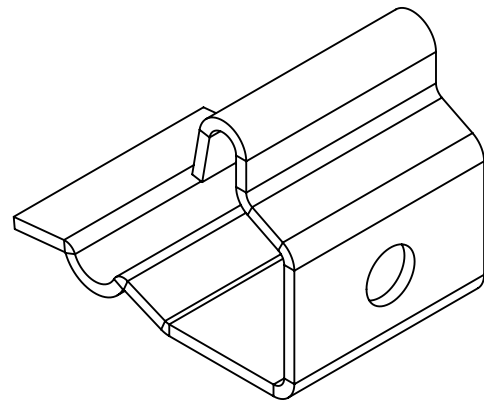

ISOMETRIC VIEW

TMS SERIES TRAY
(NOT INCLUDED)

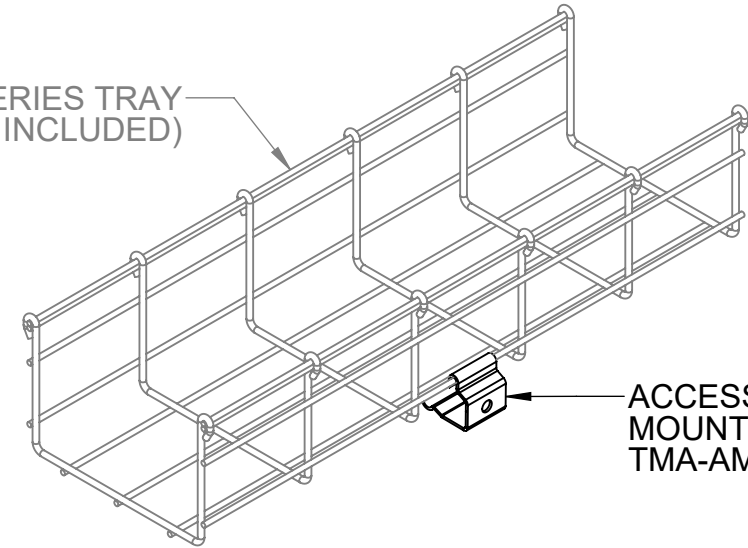

ISO INSTALLED VIEW

ACCESSORY
MOUNTING CLIP
TMA-AMC-(*)

TMA - AMC - EG

SERIES
TMA = TOUGHMESH
ACCESSORIES

TYPE
AMC = ACCESSORY
MOUNTING CLIP

(*) MATERIAL/ FINISH
EG = ELECTROPLATED ZINC
PT = PAINTED
HD = HOT-DIPPED GALVANIZED
S4 = STAINLESS STEEL 304
S6 = STAINLESS STEEL 316

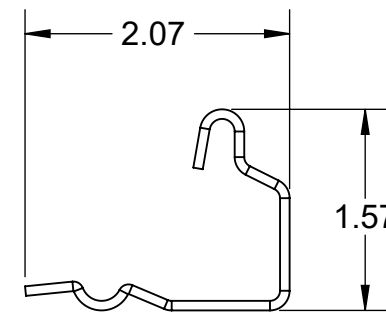

SECTION VIEW

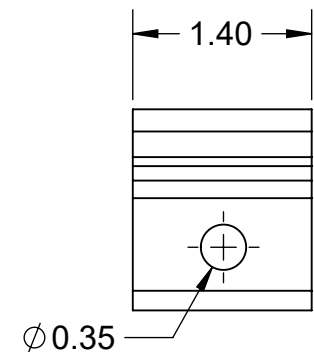

SIDE VIEW

NOTE(S):

- 1) DIMENSIONS SHOWN ARE IN INCHES UNLESS OTHERWISE NOTED.
- 2) ALL DIMENSIONS SHOWN ARE NOMINAL.
- 3) DESIGNED FOR VARIOUS SIDE MOUNTED ACCESSORIES.
- 4) SOLD IN BAG OF 10.

PROPRIETARY AND CONFIDENTIAL THE INFORMATION CONTAINED IN THIS DRAWING IS THE SOLE PROPERTY OF CT INNOVATIONS. ANY REPRODUCTION IN PART OR AS A WHOLE WITHOUT THE WRITTEN PERMISSION OF CT INNOVATIONS IS PROHIBITED.

	TITLE: TOUGHMESH ACCESSORY MOUNTING CLIP TMA-AMC-(*)		
	DRAWN BY/DATE: LW 21OCT2024	SIZE: B	DWG. NO.: CTI-S37028
APPROVED BY/DATE:	SCALE: NTS	CAD FILE NAME: CTI-S37028_C CAD SAVE DATE: Monday, October 21, 2024 5:20:50 PM	SHEET: 1 OF 1

6

5

4

3

2

1

6

5

4

3

2

1

F

F

E

E

D

D

C

C

B

B

A

A

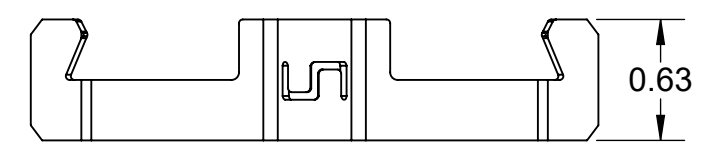
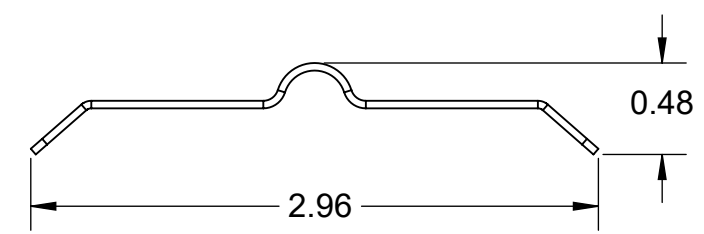
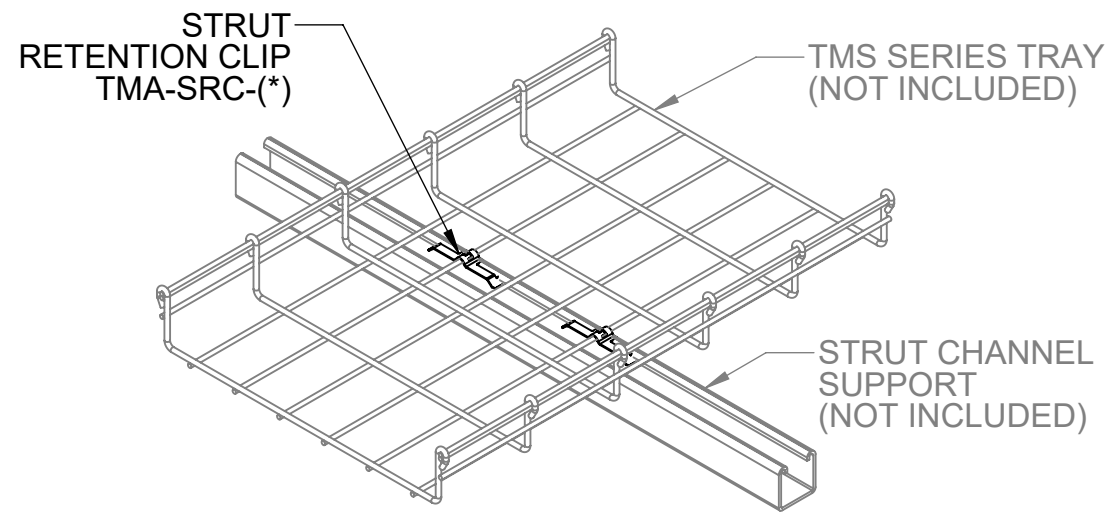
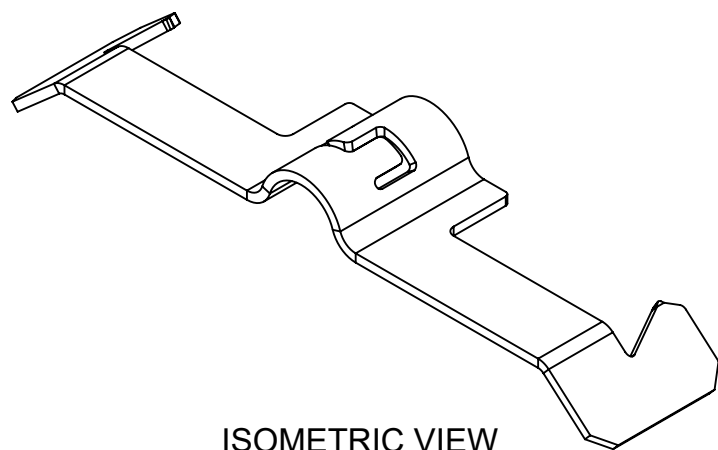

TMA - SRC - EG

SERIES
TMA = TOUGHMESH ACCESSORIES

TYPE
SRC = STRUT RETENTION CLIP

(*) MATERIAL/ FINISH
EG = ELECTROPLATED ZINC
PT = PAINTED
HD = HOT-DIPPED GALVANIZED
S4 = STAINLESS STEEL 304
S6 = STAINLESS STEEL 316

NOTE(S):

- 1) DIMENSIONS SHOWN ARE IN INCHES UNLESS OTHERWISE NOTED.
- 2) ALL DIMENSIONS SHOWN ARE NOMINAL.
- 3) STRUT RETENTION CLIP IS USED FOR 2~6" HEIGHT & 4~24" WIDTH WIREBASKET TRAY.
- 4) SOLD IN BAG OF 10.

PROPRIETARY AND CONFIDENTIAL THE INFORMATION CONTAINED IN THIS DRAWING IS THE SOLE PROPERTY OF CT INNOVATIONS. ANY REPRODUCTION IN PART OR AS A WHOLE WITHOUT THE WRITTEN PERMISSION OF CT INNOVATIONS IS PROHIBITED.

	TITLE: TOUGHMESH STRUT RETENTION CLIP TMA-SRC-(*)		
	DRAWN BY/DATE: LW 21OCT2024	SIZE: B	DWG. NO.: CTI-S37029
APPROVED BY/DATE:	SCALE: NTS	CAD FILE NAME: CTI-S37029_C CAD SAVE DATE: Monday, October 21, 2024 5:22:59 PM	SHEET: 1 OF 1

6

5

4

3

2

1

6

5

4

3

2

1

F

F

E

E

D

D

C

C

B

B

A

A

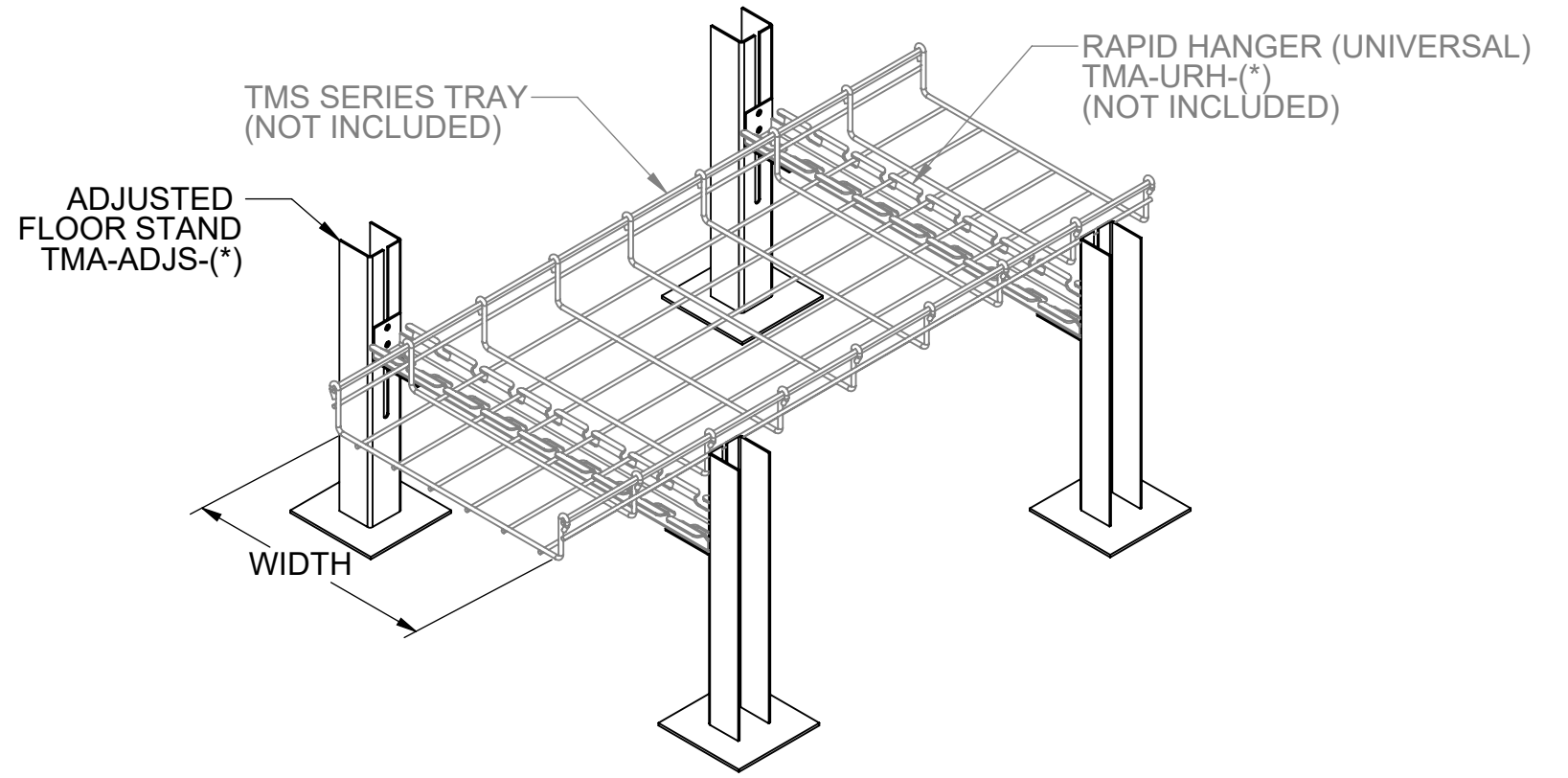

ISO INSTALLED VIEW

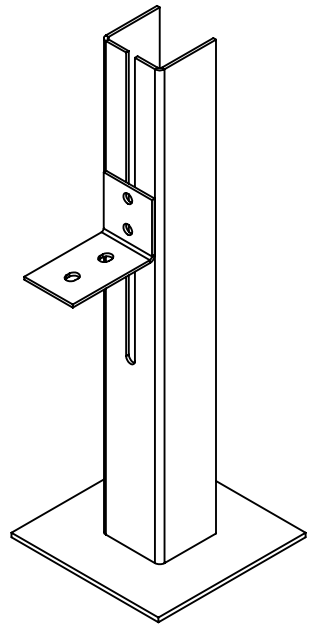

ISOMETRIC VIEW

TMA - ADJS - EG

SERIES
TMA = TOUGHMESH
ACCESSORIES

TYPE
ADJS =
ADJUSTABLE
FLOOR STAND

(*) MATERIAL/ FINISH
EG = ELECTROPLATED ZINC
HD = HOT-DIPPED GALVANIZED

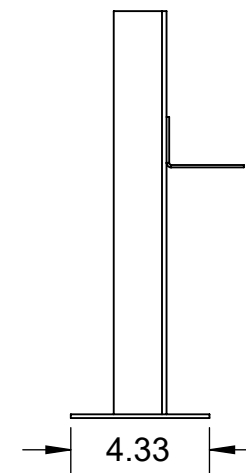

SIDE VIEW

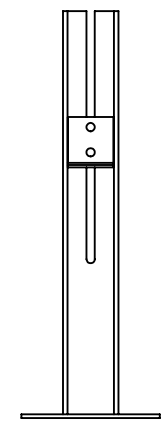

FRONT VIEW

NOTE(S):

- 1) DIMENSIONS SHOWN ARE IN INCHES UNLESS OTHERWISE NOTED.
- 2) ALL DIMENSIONS SHOWN ARE NOMINAL.

PROPRIETARY AND CONFIDENTIAL THE INFORMATION CONTAINED IN THIS DRAWING IS THE SOLE PROPERTY OF CT INNOVATIONS. ANY REPRODUCTION IN PART OR AS A WHOLE WITHOUT THE WRITTEN PERMISSION OF CT INNOVATIONS IS PROHIBITED.

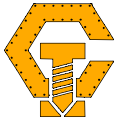
 CT INNOVATIONS		TITLE: TOUGHMESH ADJUSTABLE FLOOR STAND TMA-ADJS-(*)		
		DRAWN BY/DATE: DL 26JUL2023	SIZE: B	DWG. NO.: CTI-S37030
APPROVED BY/DATE:		SCALE: NTS	CAD FILE NAME: CTI-S37030_B CAD SAVE DATE: Tuesday, August 22, 2023 5:10:06 PM	SHEET: 1 OF 1

6

5

4

3

2

1

6

5

4

3

2

1

F

F

E

E

D

D

C

C

B

B

A

A

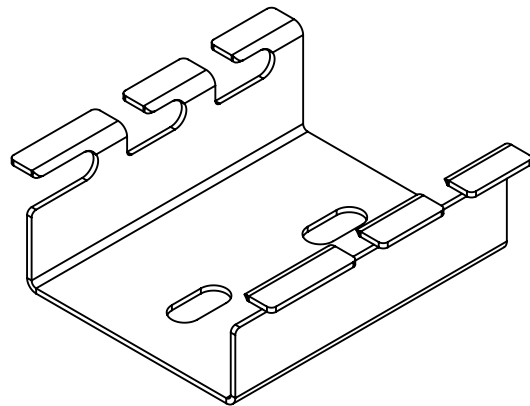

ISOMETRIC VIEW

TMA - BXCN - EG

SERIES
TMA = TOUGHMESH
ACCESSORIES

TYPE
BXCN = BOX
CONNECTOR

(*) MATERIAL/ FINISH
EG = ELECTROPLATED ZINC
PT = PAINTED
HD = HOT-DIPPED GALVANIZED
S4 = STAINLESS STEEL 304
S6 = STAINLESS STEEL 316

TMS SERIES TRAY
(NOT INCLUDED)

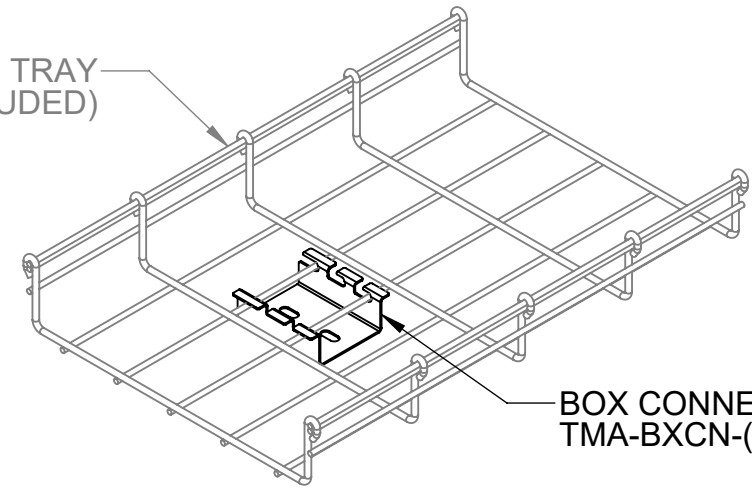

BOX CONNECTOR
TMA-BXCN-(*)

ISO INSTALLED VIEW

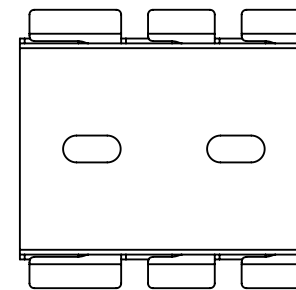

TOP VIEW

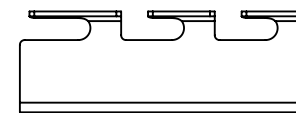

SIDE VIEW



FRONT VIEW

NOTE(S):

- 1) DESIGNED FOR ELECTRIC BOX INSTALLATION TO BASKET TRAY.
- 2) SOLD IN BAG OF 10.
- 3) ACCEPTS 1/4" HARDWARE.

PROPRIETARY AND CONFIDENTIAL THE INFORMATION CONTAINED IN THIS DRAWING IS THE SOLE PROPERTY OF CT INNOVATIONS. ANY REPRODUCTION IN PART OR AS A WHOLE WITHOUT THE WRITTEN PERMISSION OF CT INNOVATIONS IS PROHIBITED.

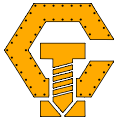
 CT INNOVATIONS	TITLE: TOUGHMESH ACCESSORY BOX CONNECTOR TMA-BXCN-(*)			
	DRAWN BY/DATE: DL 21OCT2024	SIZE: B	DWG. NO.: CTI-S37031	REV: C
	APPROVED BY/DATE:	SCALE: NTS	CAD FILE NAME: CTI-S37031_C CAD SAVE DATE: Monday, October 21, 2024 5:25:32 PM	SHEET: 1 OF 1

6

5

4

3

2

1

6

5

4

3

2

1

F

F

E

E

D

D

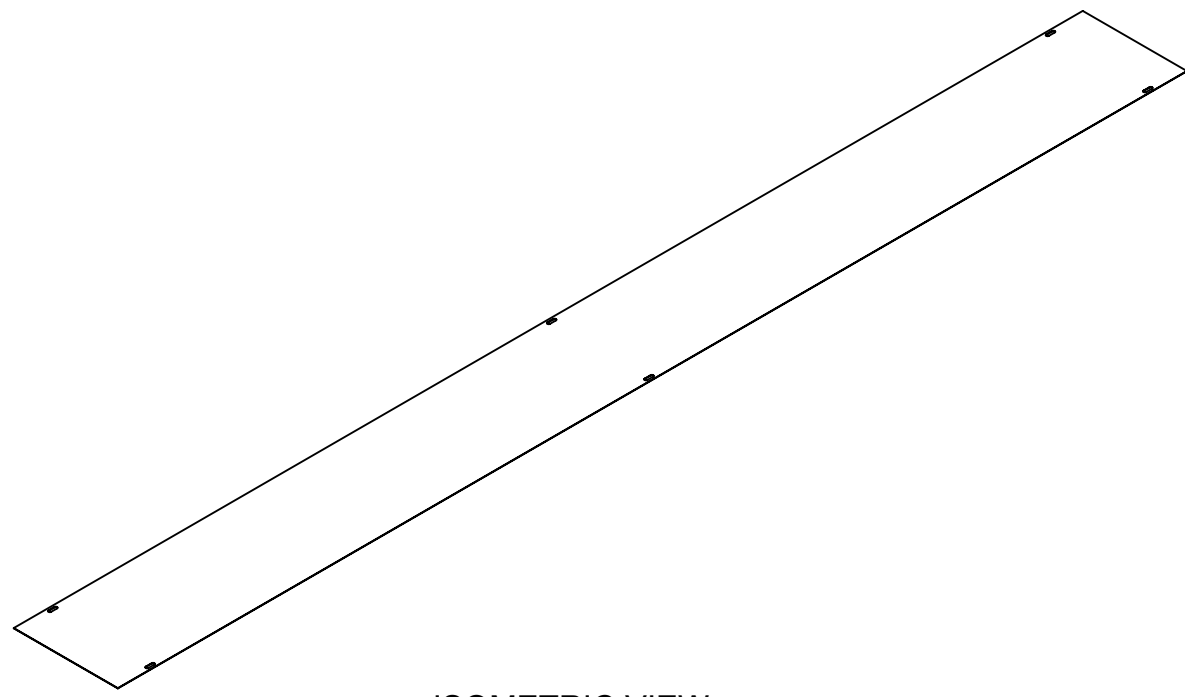

METALLIC INSERT
TMA-METI-(*)

TMS SERIES TRAY
(NOT INCLUDED)

HOLD DOWN KIT
TMA-HDKIT-(*)
(NOT INCLUDED)

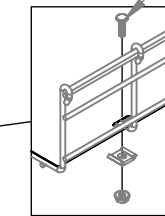

DETAIL D

ISO INSTALLED VIEW

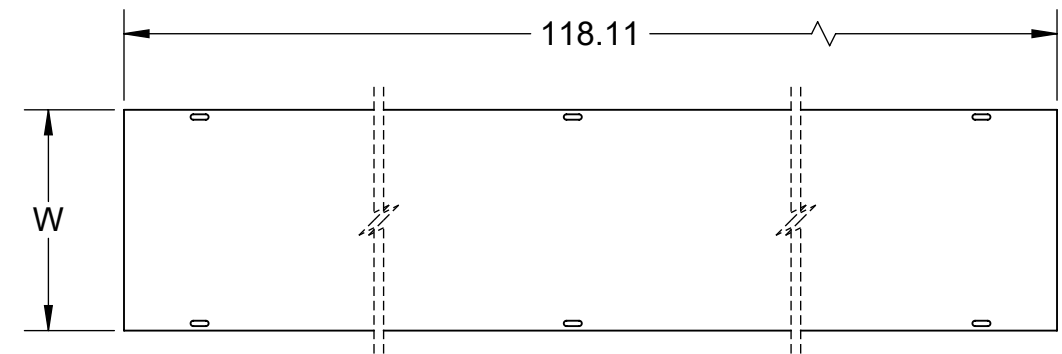

TMA - METI - 12 - EG			
SERIES	TYPE	(W)	(*) MATERIAL/ FINISH
TMA = TOUGHMESH ACCESSORIES	METI = METALLIC INSERT	NOMINAL WIDTH	EG = ELECTROPLATED ZINC PT = PAINTED FINISH HD = HOT DIPPED GALVANIZED S4 = STAINLESS STEEL 304 S6 = STAINLESS STEEL 316
		02 = 2" 06 = 6" 08 = 8" 10 = 10" 12 = 12" 16 = 16" 18 = 18" 20 = 20" 24 = 24" 30 = 30" 36 = 36"	

- NOTE(S):**
- 1) DIMENSIONS SHOWN ARE IN INCHES UNLESS OTHERWISE NOTED.
 - 2) ALL DIMENSIONS SHOWN ARE NOMINAL.
 - 3) SOLD PER PIECE WITHOUT HARDWARE.
 - 4) SIX (6) PIECES HOLD DOWN KIT "TMA-HDKIT" TO BE ORDERED SEPARATELY.

PROPRIETARY AND CONFIDENTIAL THE INFORMATION CONTAINED IN THIS DRAWING IS THE SOLE PROPERTY OF CT INNOVATIONS. ANY REPRODUCTION IN PART OR AS A WHOLE WITHOUT THE WRITTEN PERMISSION OF CT INNOVATIONS IS PROHIBITED.

 CT INNOVATIONS		TITLE: METALLIC INSERT TMA-METI-(W)-(*)	
DRAWN BY/DATE: DL 21OCT2024		SIZE: B	DWG. NO.: CTI-S37032
APPROVED BY/DATE:		SCALE: NTS	REV: B
		<small>CAD FILE NAME: CTI-S37032_A CAD SAVE DATE: Monday, October 21, 2024 5:32:09 PM</small>	SHEET: 1 OF 1

6

5

4

3

2

1

A

A

6

5

4

3

2

1

F

F

E

E

D

D

C

C

B

B

A

A

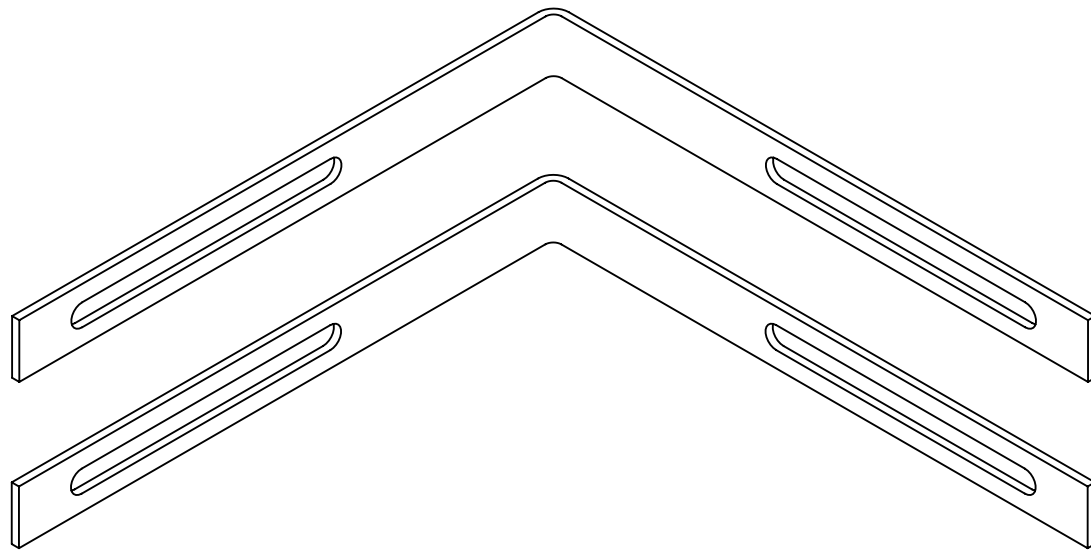

ISOMETRIC VIEW

TMS SERIES TRAY
(NOT INCLUDED)

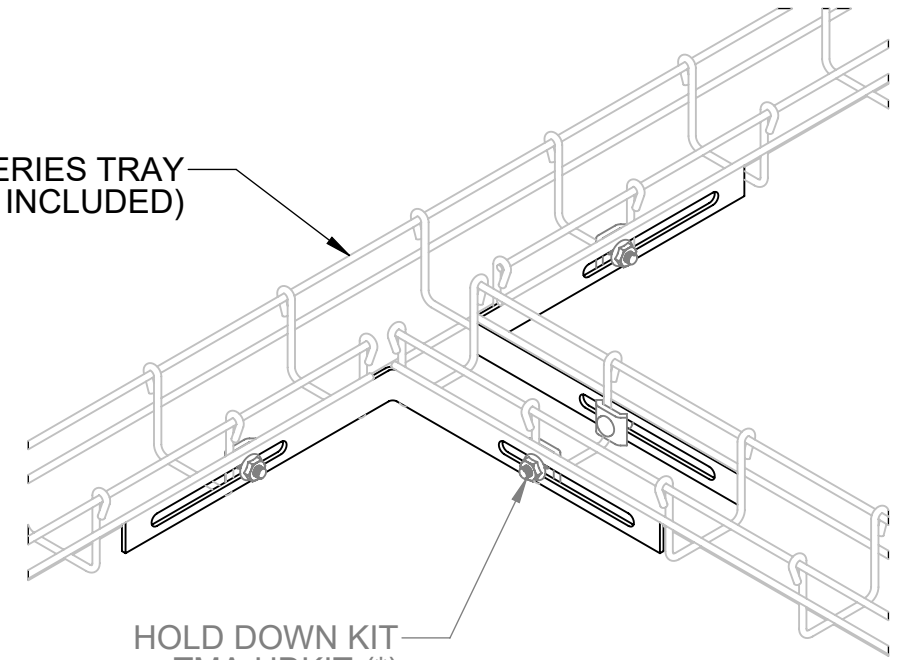

HOLD DOWN KIT
TMA-HDKIT-(*)
(NOT INCLUDED)

ISO INSTALLED VIEW

TMA - CSB - EG

SERIES
TMA = TOUGHMESH
ACCESSORIES

TYPE
CSB =
TEE/CORNER

(*) MATERIAL/ FINISH
EG = ELECTROPLATED ZINC
PT = PAINTED
HD = HOT-DIPPED GALVANIZED
S4 = STAINLESS STEEL 304
S6 = STAINLESS STEEL 316

NOTE(S):

- 1) DIMENSIONS SHOWN ARE IN INCHES UNLESS OTHERWISE NOTED.
- 2) ALL DIMENSIONS SHOWN ARE NOMINAL.
- 3) SPLICE BAR KIT USED FOR 2~6" HEIGHT & 2~8" WIDTH.
- 4) SOLD IN PAIRS.
- 5) FOUR (4) PIECES HOLD DOWN KIT "TMA-HDKIT-(*)" TO BE ORDERED SEPARATELY.

PROPRIETARY AND CONFIDENTIAL THE INFORMATION CONTAINED IN THIS DRAWING IS THE SOLE PROPERTY OF CT INNOVATIONS. ANY REPRODUCTION IN PART OR AS A WHOLE WITHOUT THE WRITTEN PERMISSION OF CT INNOVATIONS IS PROHIBITED.

 CT INNOVATIONS	TITLE: TOUGHMESH TEE/CORNER TMA-CSB-(*)		
	DRAWN BY/DATE: VA 21OCT2024	SIZE: B	DWG. NO.: CTI-S37033
APPROVED BY/DATE:	SCALE: NTS	CAD FILE NAME: TMA-EX5B_A CAD SAVE DATE: Monday, October 21, 2024 5:34:02 PM	SHEET: 1 OF 1

6

5

4

3

2

1

6

5

4

3

2

1

F

F

E

E

D

D

C

C

B

B

A

A

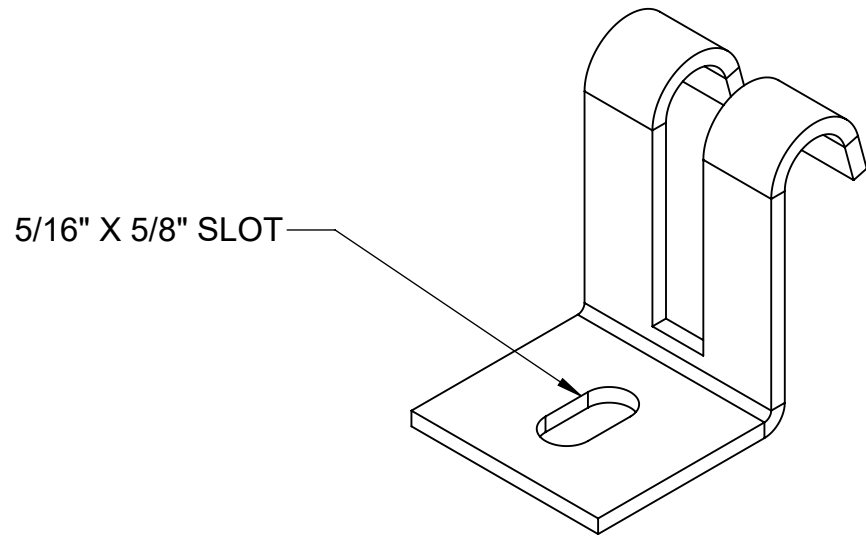

ISOMETRIC VIEW

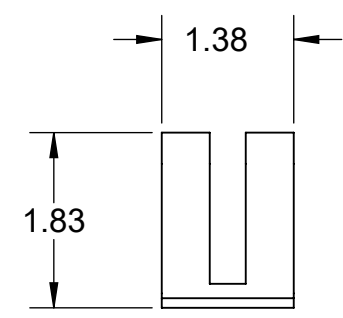

SECTION VIEW

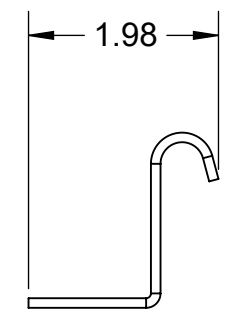

SIDE VIEW

TMA - FCLP - EG

<p>SERIES TMA = TOUGHMESH ACCESSORIES</p>	<p>TYPE FCLP = FLOOR CLIP</p>	<p>(*) MATERIAL/ FINISH EG = ELECTROPLATED ZINC PT = PAINTED HD = HOT-DIPPED GALVANIZED S4 = STAINLESS STEEL 304 S6 = STAINLESS STEEL 316</p>
---	-----------------------------------	---

NOTE(S):
 1) DIMENSIONS SHOWN ARE IN INCHES UNLESS OTHERWISE NOTED.
 2) ALL DIMENSIONS SHOWN ARE NOMINAL.
 3) SOLD IN BAG OF 10.

PROPRIETARY AND CONFIDENTIAL THE INFORMATION CONTAINED IN THIS DRAWING IS THE SOLE PROPERTY OF CT INNOVATIONS. ANY REPRODUCTION IN PART OR AS A WHOLE WITHOUT THE WRITTEN PERMISSION OF CT INNOVATIONS IS PROHIBITED.

 CT INNOVATIONS	TITLE: TOUGHMESH FLOOR CLIP TMA-FCLP-(*)		
DRAWN BY/DATE: VA 10NOV2023	SIZE: B	DWG. NO.: CTI-S37035	REV: A
APPROVED BY/DATE:	SCALE: NTS	CAD FILE NAME: TMA-FCLIP_A CAD SAVE DATE: Monday, October 21, 2024 5:35:28 PM	SHEET: 1 OF 1

6

5

4

3

2

1

6

5

4

3

2

1

F

F

E

E

D

D

C

C

B

B

A

A

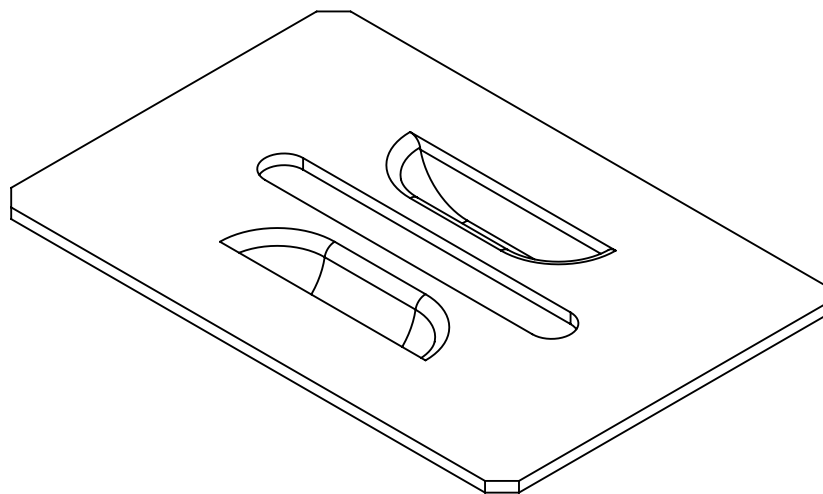

ISOMETRIC VIEW

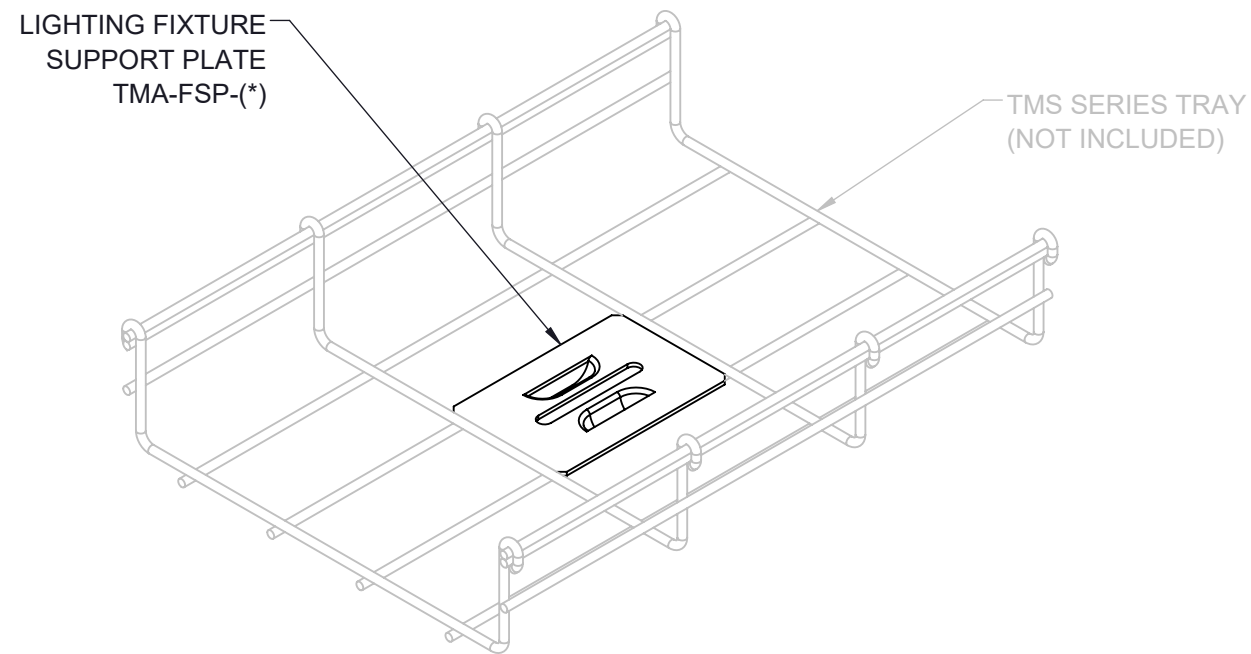

ISO INSTALLED VIEW

TMA - FSP - EG

SERIES
TMA = TOUGHMESH ACCESSORIES

TYPE
FSP = LIGHTING FIXTURE SUPPORT PLATE

(*) MATERIAL/ FINISH
EG = ELECTROPLATED ZINC
PT = PAINTED
HD = HOT-DIPPED GALVANIZED
S4 = STAINLESS STEEL 304
S6 = STAINLESS STEEL 316

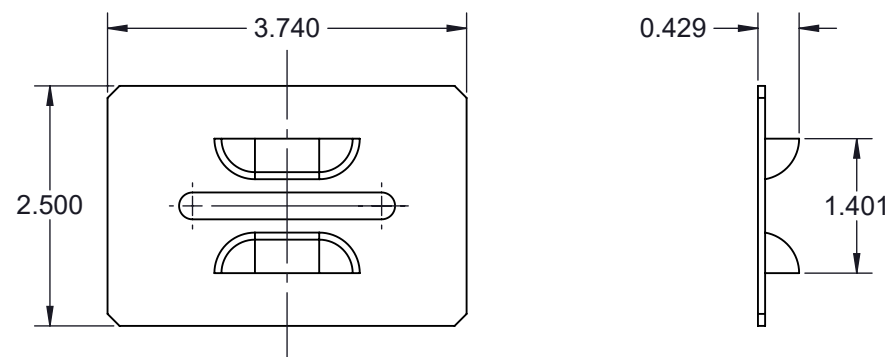

NOTE(S):

- 1) DIMENSIONS SHOWN ARE IN INCHES UNLESS OTHERWISE NOTED.
- 2) ALL DIMENSIONS SHOWN ARE NOMINAL.
- 3) SOLD IN BAG OF 10.
- 4) ACCEPTS 1/4 HARDWARE.

PROPRIETARY AND CONFIDENTIAL THE INFORMATION CONTAINED IN THIS DRAWING IS THE SOLE PROPERTY OF CT INNOVATIONS. ANY REPRODUCTION IN PART OR AS A WHOLE WITHOUT THE WRITTEN PERMISSION OF CT INNOVATIONS IS PROHIBITED.

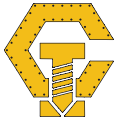
 CT INNOVATIONS	TITLE: TMA-FSP-(*) TOUGHMESH LIGHTING FIXTURE SUPPORT PLATE		
	DRAWN BY/DATE: DL 21OCT2024	SIZE: B	DWG. NO.: CTI-S37036
APPROVED BY/DATE: JDG 21OCT2024	SCALE: NTS	CAD FILE NAME: TMA-FSP_A CAD SAVE DATE: Monday, October 21, 2024 5:43:08 PM	SHEET: 1 OF 1

6

5

4

3

2

1

6

5

4

3

2

1

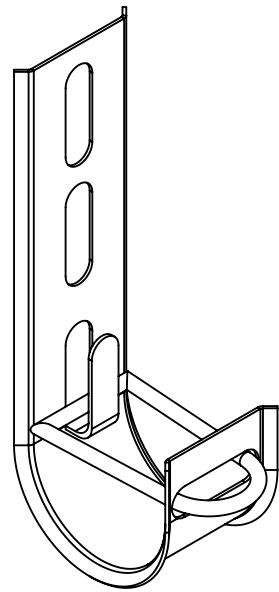

ISOMETRIC VIEW

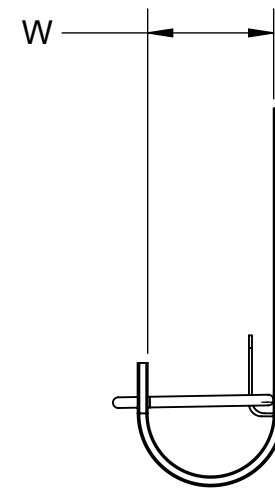

SIDE VIEW

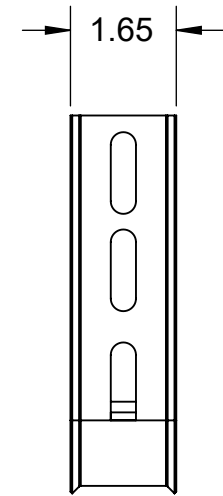

FRONT VIEW

TMA - JHOOK - 100 - EG

SERIES
TMA = TOUGHMESH
ACCESSORIES

TYPE
JHOOK = J HOOK

W
100 = 1.0"
125 = 1.25"
150 = 1.5"
200 = 2.0"
400 = 4.0"

(*) MATERIAL/ FINISH
EG = ELECTROPLATED ZINC
HG = HOT DIPPED GALVANIZED
PT = PAINTED

NOTE(S):

- 1) DIMENSIONS SHOWN ARE IN INCHES UNLESS OTHERWISE NOTED.
- 2) ALL DIMENSIONS SHOWN ARE NOMINAL.
- 3) SOLD PER PIECE.

PROPRIETARY AND CONFIDENTIAL THE INFORMATION CONTAINED IN THIS DRAWING IS THE SOLE PROPERTY OF CT INNOVATIONS. ANY REPRODUCTION IN PART OR AS A WHOLE WITHOUT THE WRITTEN PERMISSION OF CT INNOVATIONS IS PROHIBITED.

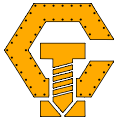
 CT INNOVATIONS	TITLE: TMA-JHOOK-(W)-(*) J HOOK TYPE CABLE SUPPORT		
	DRAWN BY/DATE: VA 21OCT2024	SIZE: B	DWG. NO.: CTI-S37037
APPROVED BY/DATE:	SCALE: NTS	CAD FILE NAME: TMA-JHOOK_A CAD SAVE DATE: Monday, October 21, 2024 5:44:20 PM	SHEET: 1 OF 1

6

5

4

3

2

1

6

5

4

3

2

1

F

F

E

E

D

D

C

C

B

B

A

A

TMS SERIES TRAY
(NOT INCLUDED)

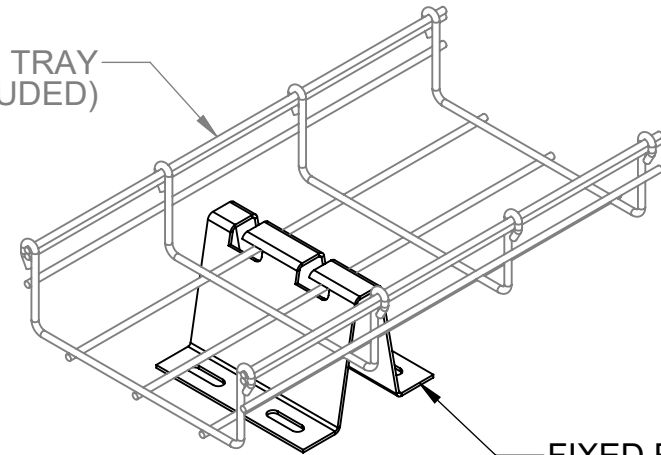

FIXED FLOOR SUPPORT
TMA-FFS-(*)

ISO INSTALLED VIEW

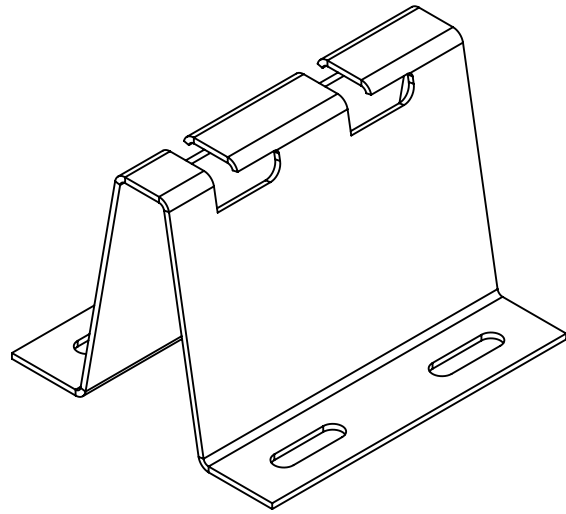

ISOMETRIC VIEW

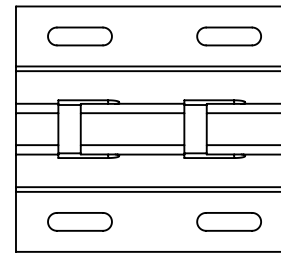

TOP VIEW

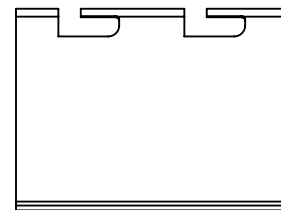

SIDE VIEW

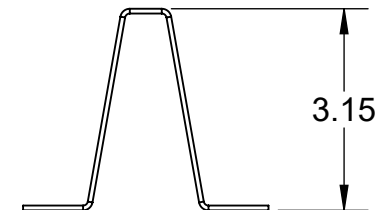

FRONT VIEW

TMA - FFS - EG

SERIES
TMA = TOUGHMESH
ACCESSORIES

TYPE
FFS = FIXED FLOOR
SUPPORT

(*) MATERIAL/ FINISH
EG = ELECTROPLATED ZINC
HD = HOT-DIPPED GALVANIZED

NOTE(S):

1) DESIGNED FOR BASKET TRAY FLOOR SUPPORT MOUNT.

PROPRIETARY AND CONFIDENTIAL THE INFORMATION CONTAINED IN THIS DRAWING IS THE SOLE PROPERTY OF CT INNOVATIONS. ANY REPRODUCTION IN PART OR AS A WHOLE WITHOUT THE WRITTEN PERMISSION OF CT INNOVATIONS IS PROHIBITED.

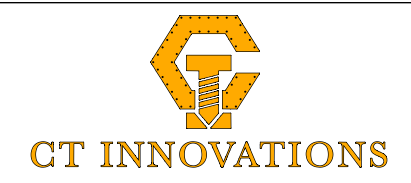

TITLE:
**TMA-FFS-(*)
TOUGHMESH FIXED FLOOR SUPPORT**

DRAWN BY/DATE:
DL 03OCT2023

SIZE:
B

DWG. NO.:
CTI-S37038

REV:
A

APPROVED BY/DATE:

SCALE:
NTS

CAD FILE NAME: CTI-S37038_A
CAD SAVE DATE: Wednesday, October 4, 2023 10:57:33 PM

SHEET:
1 OF 1

6

5

4

3

2

1

6

5

4

3

2

1

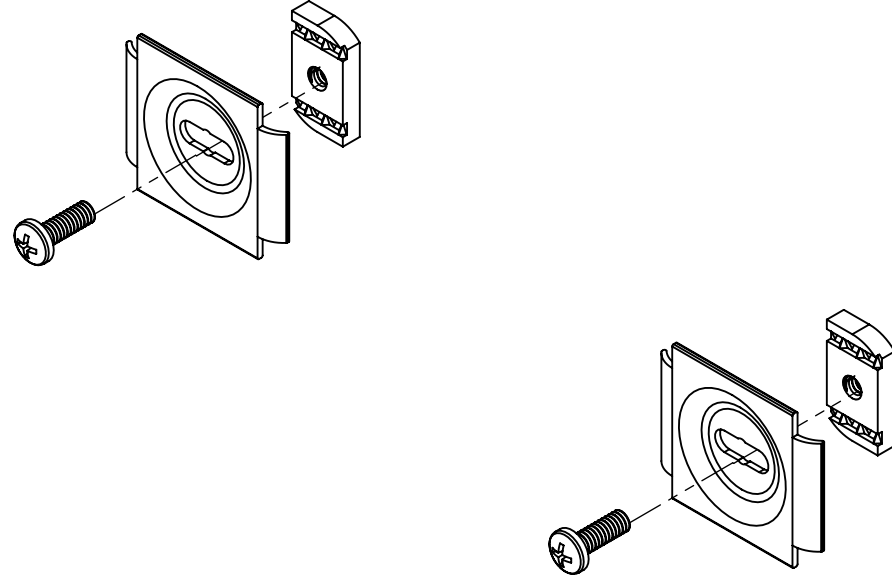

ISOMETRIC VIEW

TMA - WLKIT - EG

SERIES
TMA = TOUGHMESH
ACCESSORIES

TYPE
WLKIT = WALL KIT

(*) MATERIAL/ FINISH
EG = ELECTROPLATED ZINC
PT = PAINTED
HD = HOT-DIPPED GALVANIZED
S4 = STAINLESS STEEL 304
S6 = STAINLESS STEEL 316

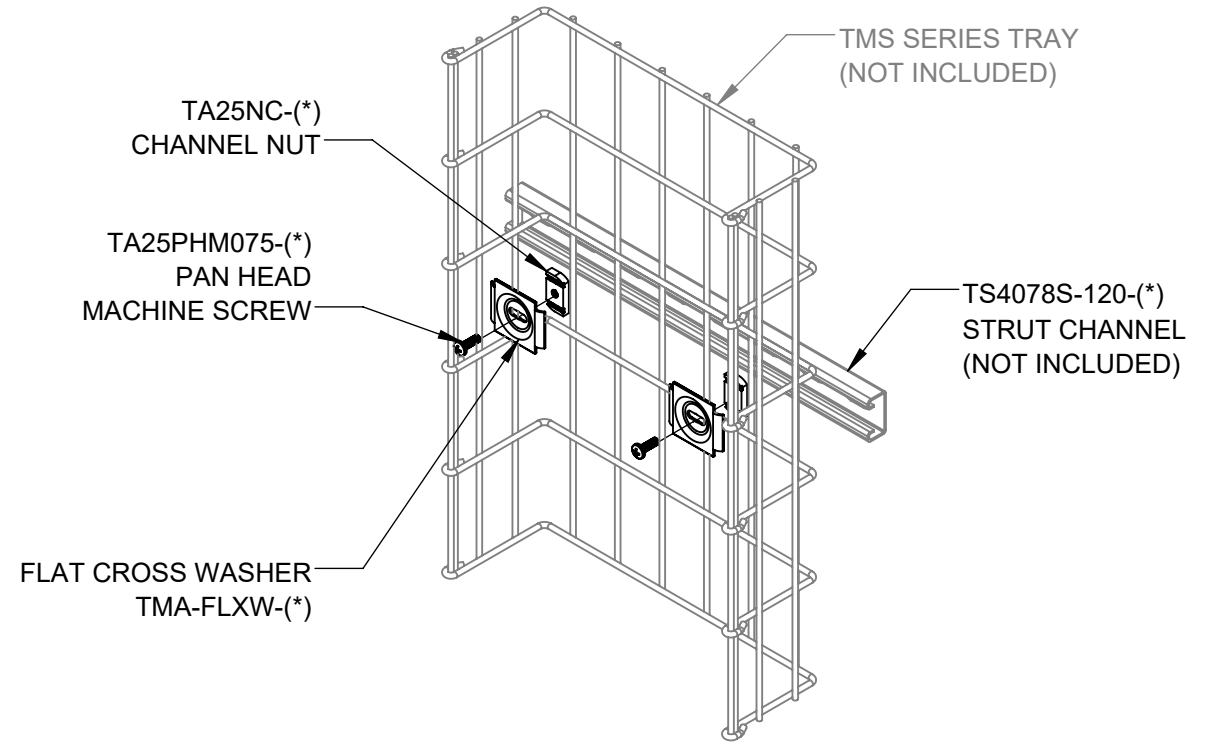

ISO ASSEMBLY VIEW

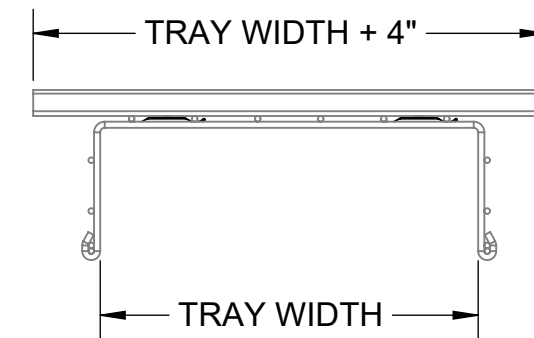

TOP VIEW

NOTE(S):

- 1) DIMENSIONS SHOWN ARE IN INCHES UNLESS OTHERWISE NOTED.
- 2) ALL DIMENSIONS SHOWN ARE NOMINAL.
- 3) USED TO SECURE BASKET TRAY TO THE SUPPORT.
- 4) SOLD IN BAG OF 20.

PROPRIETARY AND CONFIDENTIAL THE INFORMATION CONTAINED IN THIS DRAWING IS THE SOLE PROPERTY OF CT INNOVATIONS. ANY REPRODUCTION IN PART OR AS A WHOLE WITHOUT THE WRITTEN PERMISSION OF CT INNOVATIONS IS PROHIBITED.

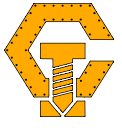
 CT INNOVATIONS	TITLE: TOUGHMESH WALL KIT TMA-WLKIT-(*)		
	DRAWN BY/DATE: DL 21OCT2024	SIZE: B	DWG. NO.: CTI-S37039
APPROVED BY/DATE: JDG 21OCT2024	SCALE: NTS	CAD FILE NAME: CTI-S37039_C CAD SAVE DATE: Monday, October 21, 2024 5:45:08 PM	SHEET: 1 OF 1

6

5

4

3

2

1

6

5

4

3

2

1

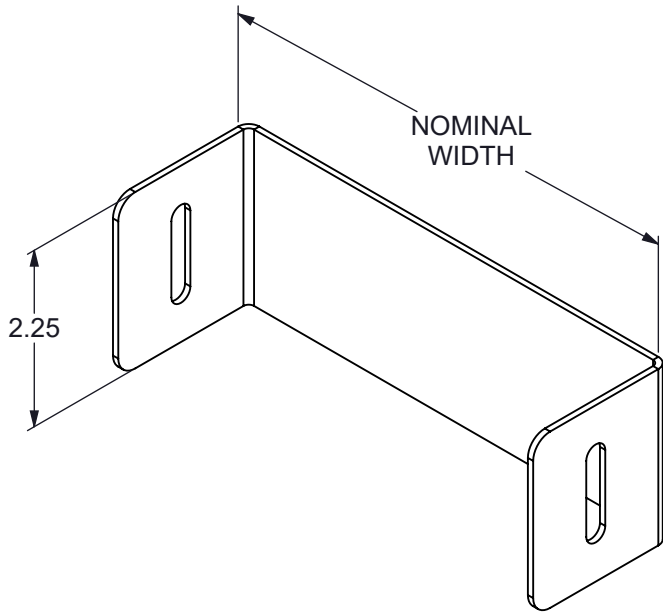

TMS SERIES TRAY
(NOT INCLUDED)

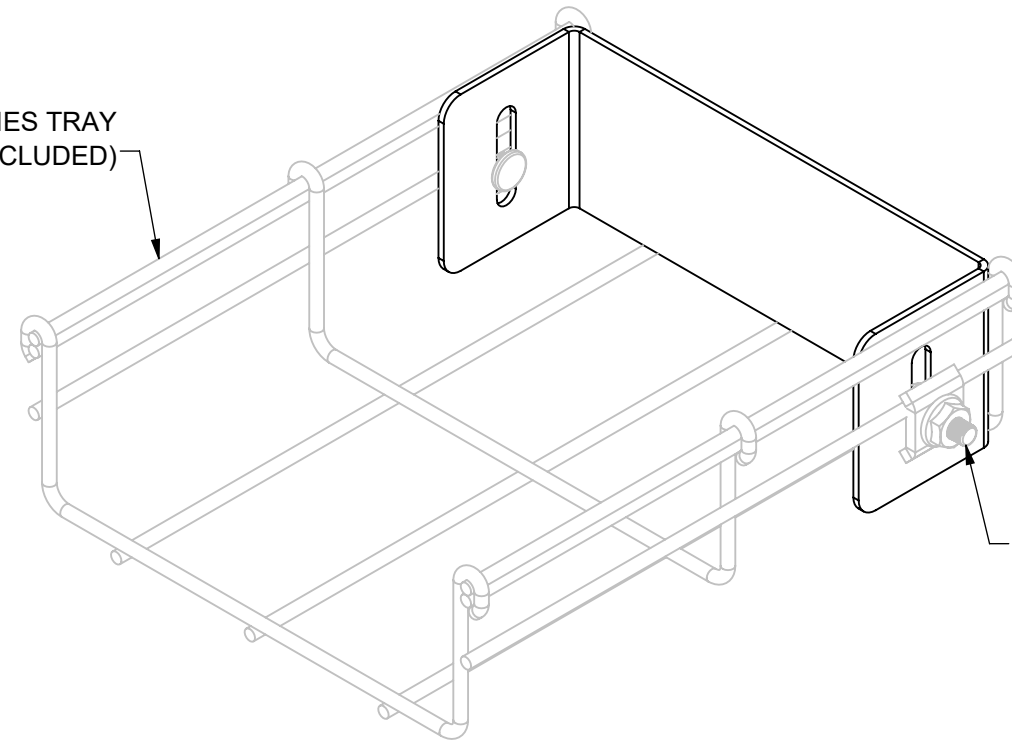

TMA-HDKIT-(*)
(NOT INCLUDED)
SEE NOTE 3

ISO INSTALLED VIEW

TMA - BLIND - 2 X 06 - EG

SERIES
TMA = TOUGHMESH
ACCESSORIES

BLIND = BLIND
END

NOMINAL
HEIGHT
2 = 2.25"

NOMINAL
WIDTH
02 = 2"
04 = 4"
06 = 6"
08 = 8"
10 = 10"
12 = 12"
16 = 16"
18 = 18"
20 = 20"
24 = 24"
30 = 30"
36 = 36"

(*) MATERIAL/ FINISH
EG = ELECTROPLATED ZINC
PT = PAINTED FINISH
S4 = STAINLESS STEEL 304
TG = TOUGH GALVANIZED
S6 = STAINLESS STEEL 316

- NOTES:
1) DIMENSIONS SHOWN ARE IN INCHES UNLESS OTHERWISE NOTED.
2) ALL DIMENSIONS SHOWN ARE NOMINAL.
3) TWO (2) PIECES HOLD DOWN KIT "TMA-HDKIT-(*)" TO BE ORDERED SEPARATELY.
4) SOLD PER PIECE.

PROPRIETARY AND CONFIDENTIAL THE INFORMATION CONTAINED IN THIS DRAWING IS THE SOLE PROPERTY OF CT INNOVATIONS. ANY REPRODUCTION IN PART OR AS A WHOLE WITHOUT THE WRITTEN PERMISSION OF CT INNOVATIONS IS PROHIBITED.

		TITLE: TMA-BLIND-2X(W)-(MATERIAL/FINISH) BLIND END, 2" HIGH		
		DRAWN BY/DATE: DL 21OCT2024	SIZE: B	DWG. NO.: CTI-S37040
APPROVED BY/DATE: JDG 21OCT2024		SCALE: NTS	CAD FILE NAME: TMA-BLIND-(H)-(W)_B CAD SAVE DATE: Monday, October 21, 2024 5:50:10 PM	SHEET: 1 OF 1

6

5

4

3

2

1

6

5

4

3

2

1

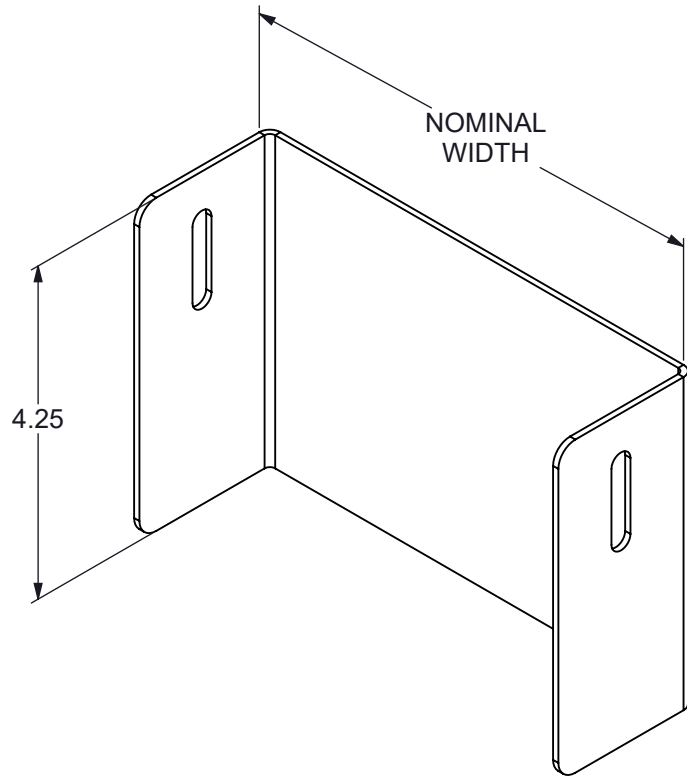

TMS SERIES TRAY
(NOT INCLUDED)

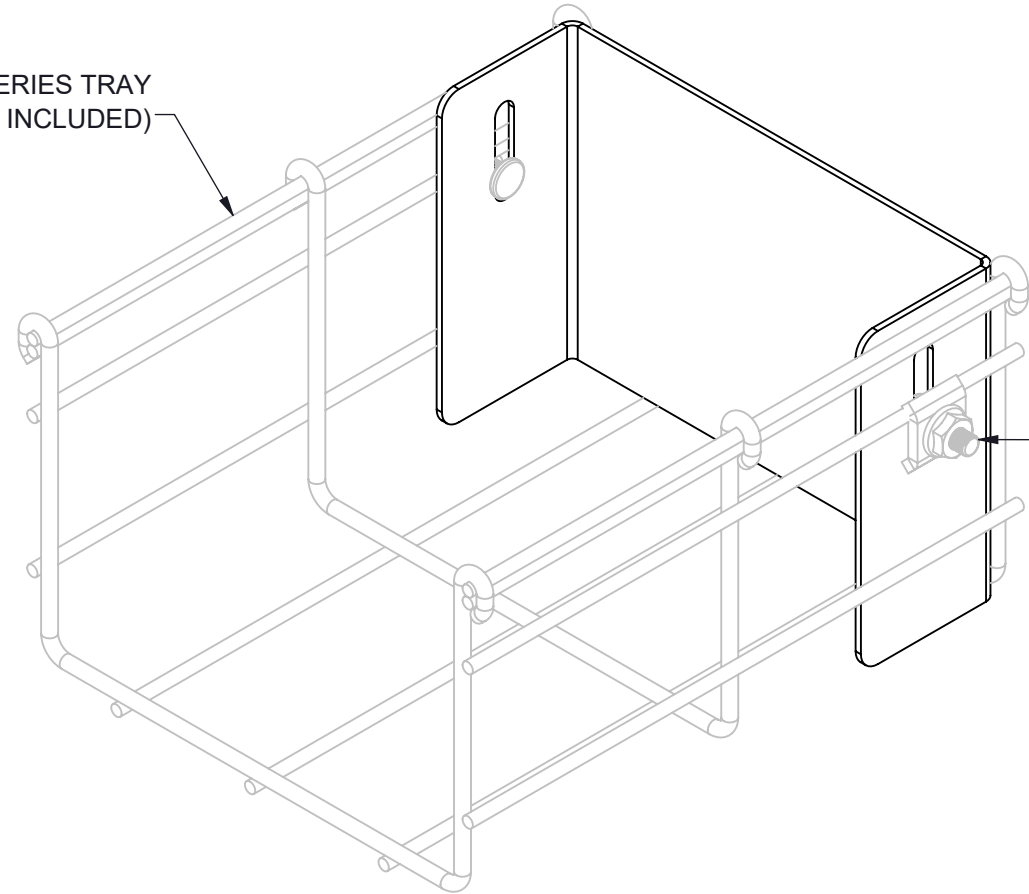

TMA-HDKIT-(*)
(NOT INCLUDED)
SEE NOTE 3

ISO INSTALLED VIEW

TMA - BLIND - 4 X 06 - EG

SERIES
TMA = TOUGHMESH
ACCESSORIES

BLIND = BLIND
END

NOMINAL
HEIGHT
4 = 4.25"

NOMINAL
WIDTH
04 = 4"
06 = 6"
08 = 8"
10 = 10"
12 = 12"
16 = 16"
18 = 18"
20 = 20"
24 = 24"
30 = 30"
36 = 36"

(*) MATERIAL/ FINISH
EG = ELECTROPLATED ZINC
PT = PAINTED FINISH
S4 = STAINLESS STEEL 304
TG = TOUGH GALVANIZED
S6 = STAINLESS STEEL 316

- NOTES:
1) DIMENSIONS SHOWN ARE IN INCHES UNLESS OTHERWISE NOTED.
2) ALL DIMENSIONS SHOWN ARE NOMINAL.
3) TWO (2) PIECES HOLD DOWN KIT "TMA-HDKIT-(*)" TO BE ORDERED SEPARATELY.
4) SOLD PER PIECE.

PROPRIETARY AND CONFIDENTIAL THE INFORMATION CONTAINED IN THIS DRAWING IS THE SOLE PROPERTY OF CT INNOVATIONS. ANY REPRODUCTION IN PART OR AS A WHOLE WITHOUT THE WRITTEN PERMISSION OF CT INNOVATIONS IS PROHIBITED.

		TITLE: TMA-BLIND-4X(W)-(MATERIAL/FINISH) BLIND END, 4" HIGH		
		DRAWN BY/DATE: DL 21OCT2024	SIZE: B	DWG. NO.: CTI-S37047
APPROVED BY/DATE: JDG 21OCT2024		SCALE: NTS	CAD FILE NAME: TMA-BLIND-(H)-(W)_B CAD SAVE DATE: Monday, October 21, 2024 5:52:29 PM	SHEET: 1 OF 1

6

5

4

3

2

1

A

A

B

B

C

C

D

D

E

E

F

F

6

5

4

3

2

1

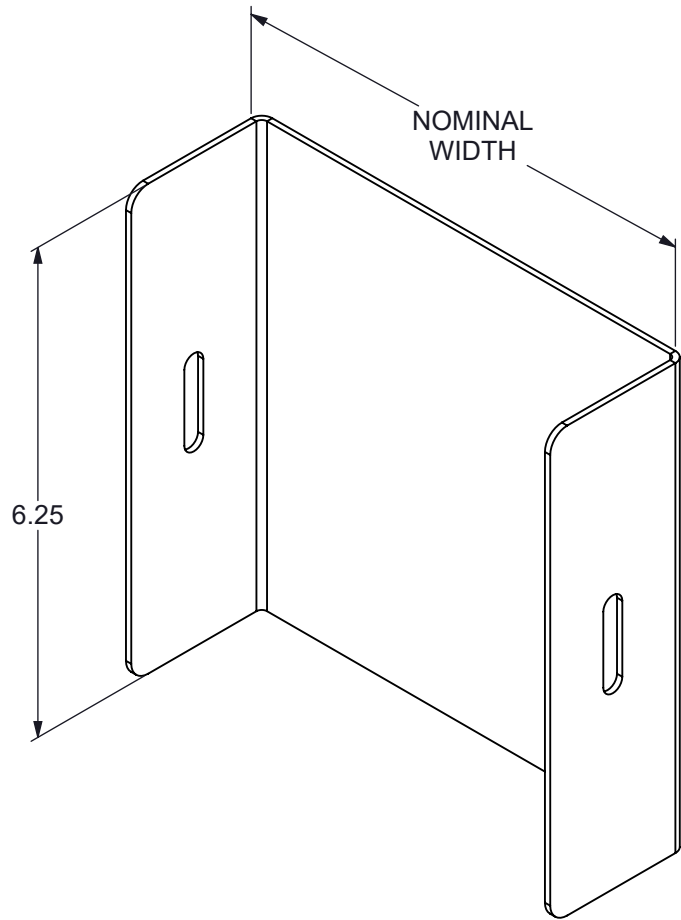

TMS SERIES TRAY
(NOT INCLUDED)

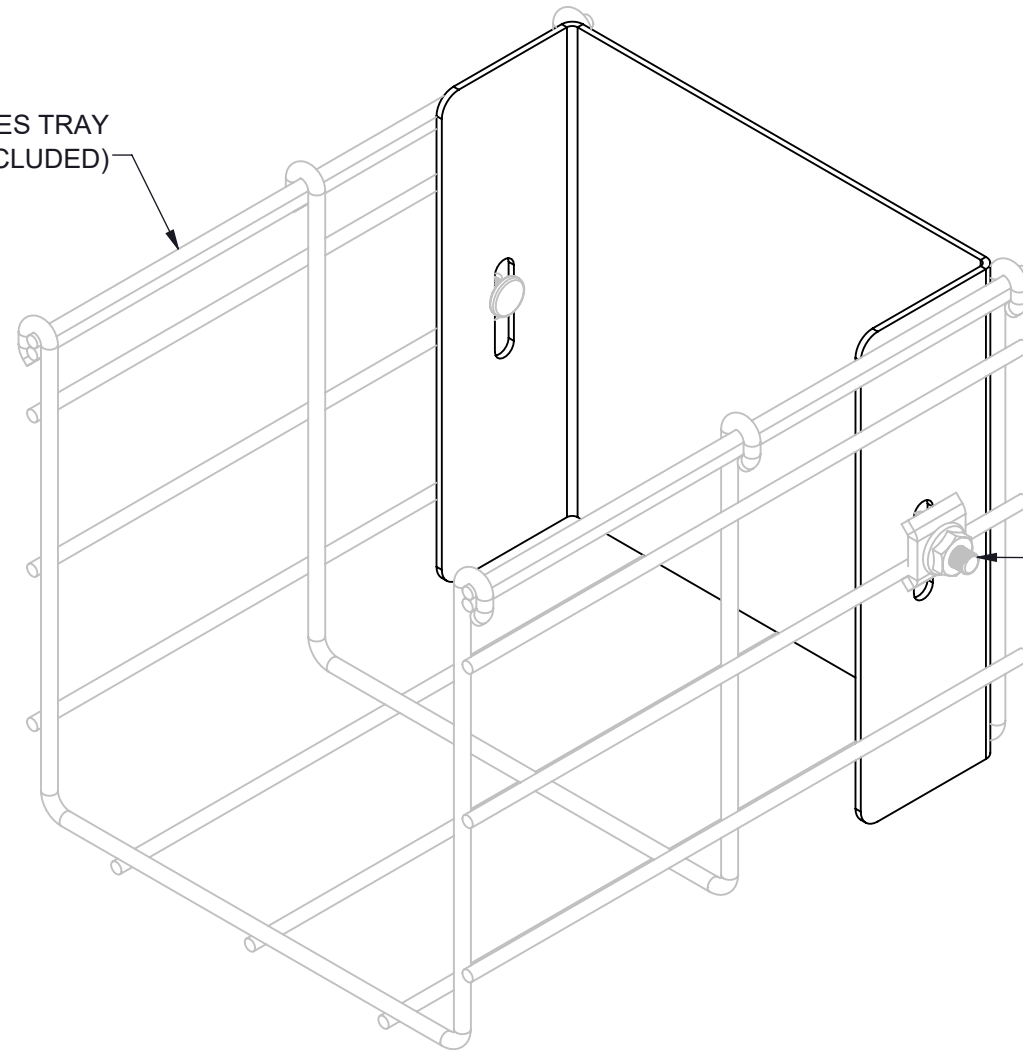

TMA-HDKIT-(*)
(NOT INCLUDED)
SEE NOTE 3

ISO INSTALLED VIEW

TMA - BLIND - 6 X 06 - EG

SERIES
TMA = TOUGHMESH
ACCESSORIES

BLIND = BLIND
END

NOMINAL
HEIGHT
6 = 6.25"

NOMINAL
WIDTH
06 = 6"
08 = 8"
10 = 10"
12 = 12"
16 = 16"
18 = 18"
20 = 20"
24 = 24"
30 = 30"
36 = 36"

(*) MATERIAL/ FINISH
EG = ELECTROPLATED ZINC
PT = PAINTED FINISH
S4 = STAINLESS STEEL 304
TG = TOUGH GALVANIZED
S6 = STAINLESS STEEL 316

- NOTES:
1) DIMENSIONS SHOWN ARE IN INCHES UNLESS OTHERWISE NOTED.
2) ALL DIMENSIONS SHOWN ARE NOMINAL.
3) TWO (2) PIECES HOLD DOWN KIT "TMA-HDKIT-(*)" TO BE ORDERED SEPARATELY.
4) SOLD PER PIECE.

PROPRIETARY AND CONFIDENTIAL THE INFORMATION CONTAINED IN THIS DRAWING IS THE SOLE PROPERTY OF CT INNOVATIONS. ANY REPRODUCTION IN PART OR AS A WHOLE WITHOUT THE WRITTEN PERMISSION OF CT INNOVATIONS IS PROHIBITED.



TITLE:
**TMA-BLIND-6X(W)-(MATERIAL/FINISH)
BLIND END, 6" HIGH**

DRAWN BY/DATE:
DL 30SEP2024

SIZE: **B** DWG. NO.: **CTI-S37054** REV: **B**

APPROVED BY/DATE:
JDG 24MAY2024

SCALE: **NTS** CAD FILE NAME: TMA-BLIND-(H)-(W)_B
CAD SAVE DATE: Monday, October 21, 2024 5:55:01 PM

SHEET:
1 OF 1

6

5

4

3

2

1

A

A

B

B

C

C

D

D

E

E

F

F

6

5

4

3

2

1

F

F

E

E

D

D

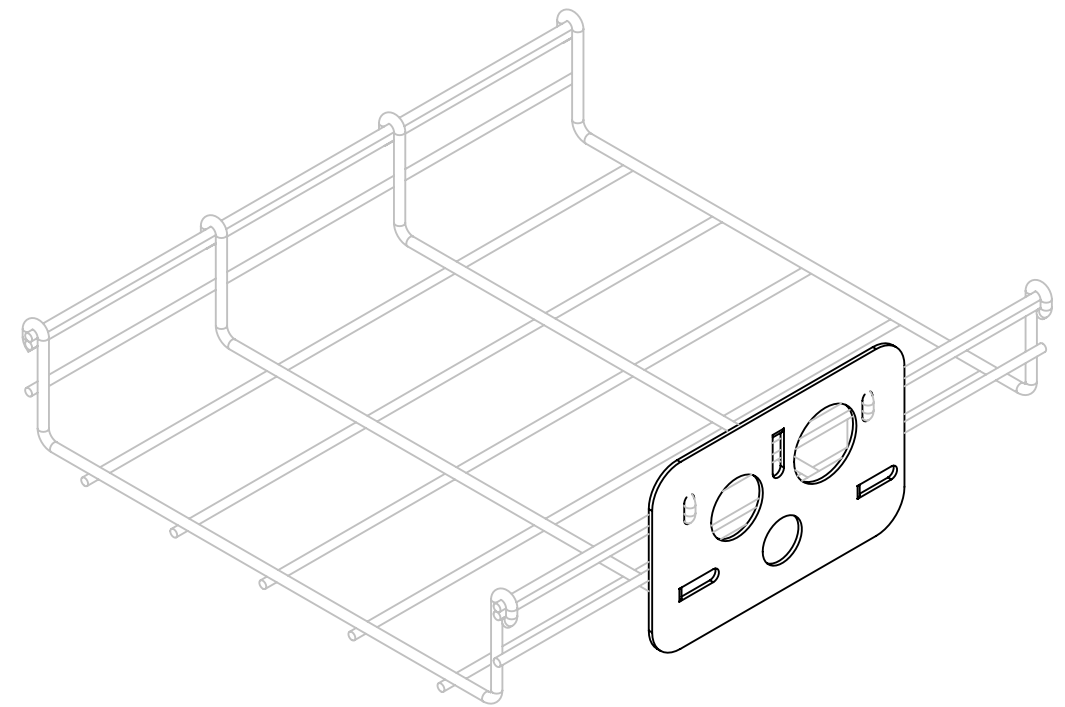
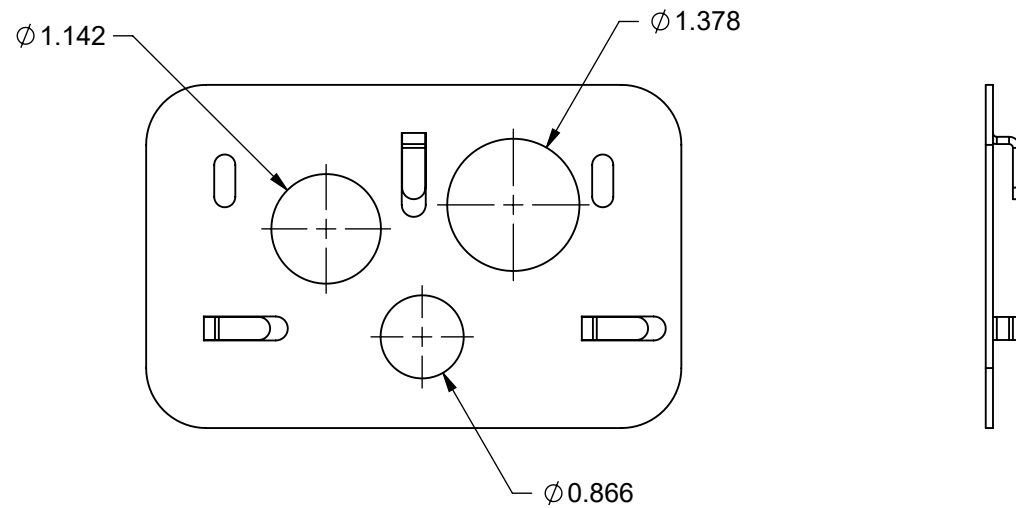

ISOMETRIC VIEW

TMA - STBU - EG

SERIES
TMA = TOUGHMESH
ACCESSORIES

TYPE
STBU = UNIVERSAL
TUBE OUTPUT

(*) MATERIAL/ FINISH
EG = ELECTROPLATED ZINC
PT = PAINTED
HD = HOT-DIPPED GALVANIZED
S4 = STAINLESS STEEL 304
S6 = STAINLESS STEEL 316

NOTE(S):

- 1) DIMENSIONS SHOWN ARE IN INCHES UNLESS OTHERWISE NOTED.
- 2) ALL DIMENSIONS SHOWN ARE NOMINAL.
- 3) SOLD IN BAG OF 10.

PROPRIETARY AND CONFIDENTIAL THE INFORMATION CONTAINED IN THIS DRAWING IS THE SOLE PROPERTY OF CT INNOVATIONS. ANY REPRODUCTION IN PART OR AS A WHOLE WITHOUT THE WRITTEN PERMISSION OF CT INNOVATIONS IS PROHIBITED.

 CT INNOVATIONS	TITLE: TMA-STBU-(*) UNIVERSAL TUBE OUTPUT PLATE FOR 3/4", 1" & 1-1/4" DIAMETER CONDUIT		
	DRAWN BY/DATE: DL 21OCT2024	SIZE: B	DWG. NO.: CTI-S37073
APPROVED BY/DATE: JDG 21OCT2024	SCALE: NTS	CAD FILE NAME: CTI-S37073_A CAD SAVE DATE: Monday, October 21, 2024 5:58:56 PM	SHEET: 1 OF 1

6

5

4

3

2

1

A

A

6

5

4

3

2

1

F

F

E

E

D

D

C

C

B

B

A

A

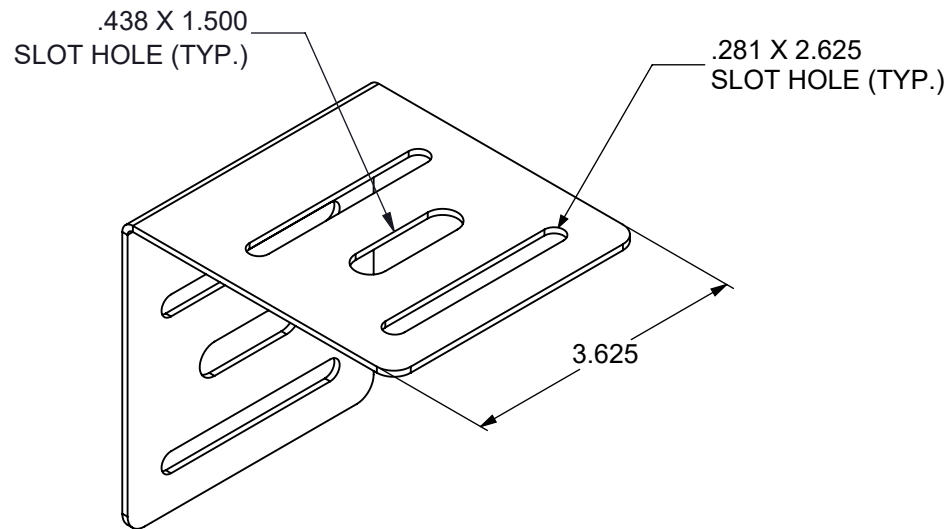

ISOMETRIC VIEW

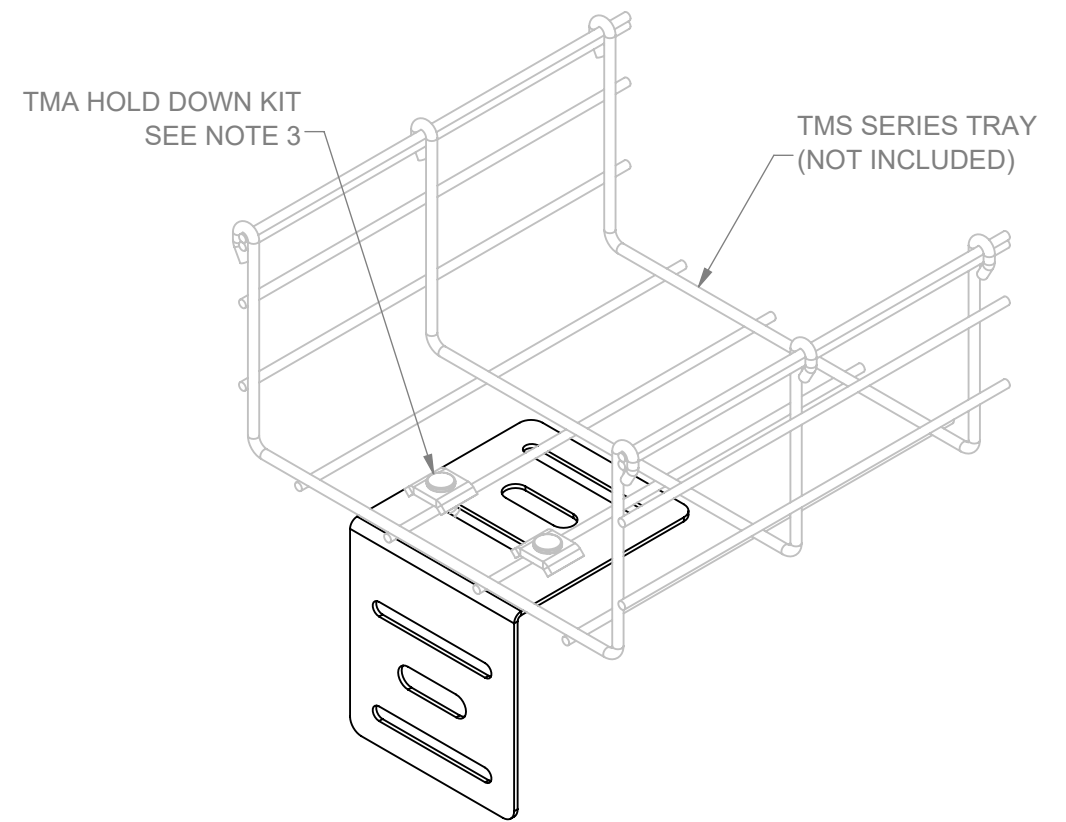

ISO INSTALLED VIEW

TMA - TERMBRKT - EG

SERIES
TMA = TOUGHMESH ACCESSORIES

TYPE:
TERMBRKT = WALL TERMINATION BRACKET

(*) MATERIAL/ FINISH
EG = ELECTROPLATED ZINC
PT = PAINTED FINISH
S4 = STAINLESS STEEL 304
S6 = STAINLESS STEEL 316

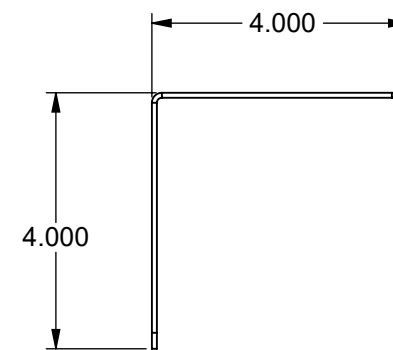

SECTION VIEW

- NOTES:
- 1) DIMENSIONS SHOWN ARE IN INCHES UNLESS OTHERWISE NOTED.
 - 2) ALL DIMENSIONS SHOWN ARE NOMINAL.
 - 3) SOLD PER PIECE.
 - 4) TWO (2) PIECES HOLD DOWN KIT "TMA-HDKIT-(*)" TO BE ORDERED SEPARATELY.
 - 5) WALL ATTACHMENT HARDWARE TO BE ORDERED SEPARATELY.

PROPRIETARY AND CONFIDENTIAL THE INFORMATION CONTAINED IN THIS DRAWING IS THE SOLE PROPERTY OF CT INNOVATIONS. ANY REPRODUCTION IN PART OR AS A WHOLE WITHOUT THE WRITTEN PERMISSION OF CT INNOVATIONS IS PROHIBITED.

	TITLE: TMA-TERMBRKT-(MATERIAL/FINISH) WALL TERMINATION BRACKET		
	DRAWN BY/DATE: DL 21OCT2024	SIZE: B	DWG. NO.: CTI-S37076
APPROVED BY/DATE:	SCALE: NTS	CAD FILE NAME: TMA-TERMBRKT_A CAD SAVE DATE: Monday, October 21, 2024 6:01:41 PM	SHEET: 1 OF 1

6

5

4

3

2

1

6

5

4

3

2

1

F

F

E

E

D

D

C

C

B

B

A

A

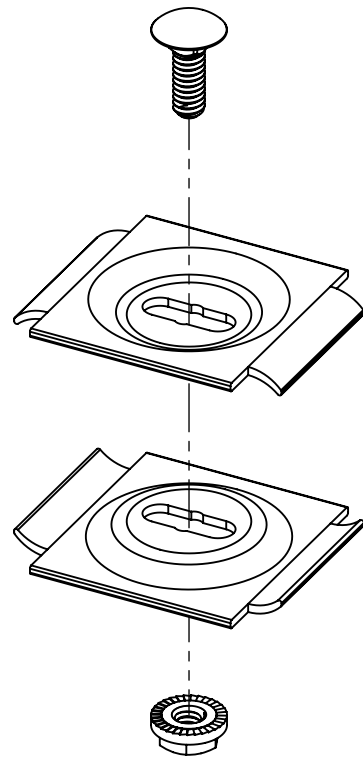

SPLICE HORIZONTAL
ADJUSTABLE KIT
TMA-SHAK-(*)

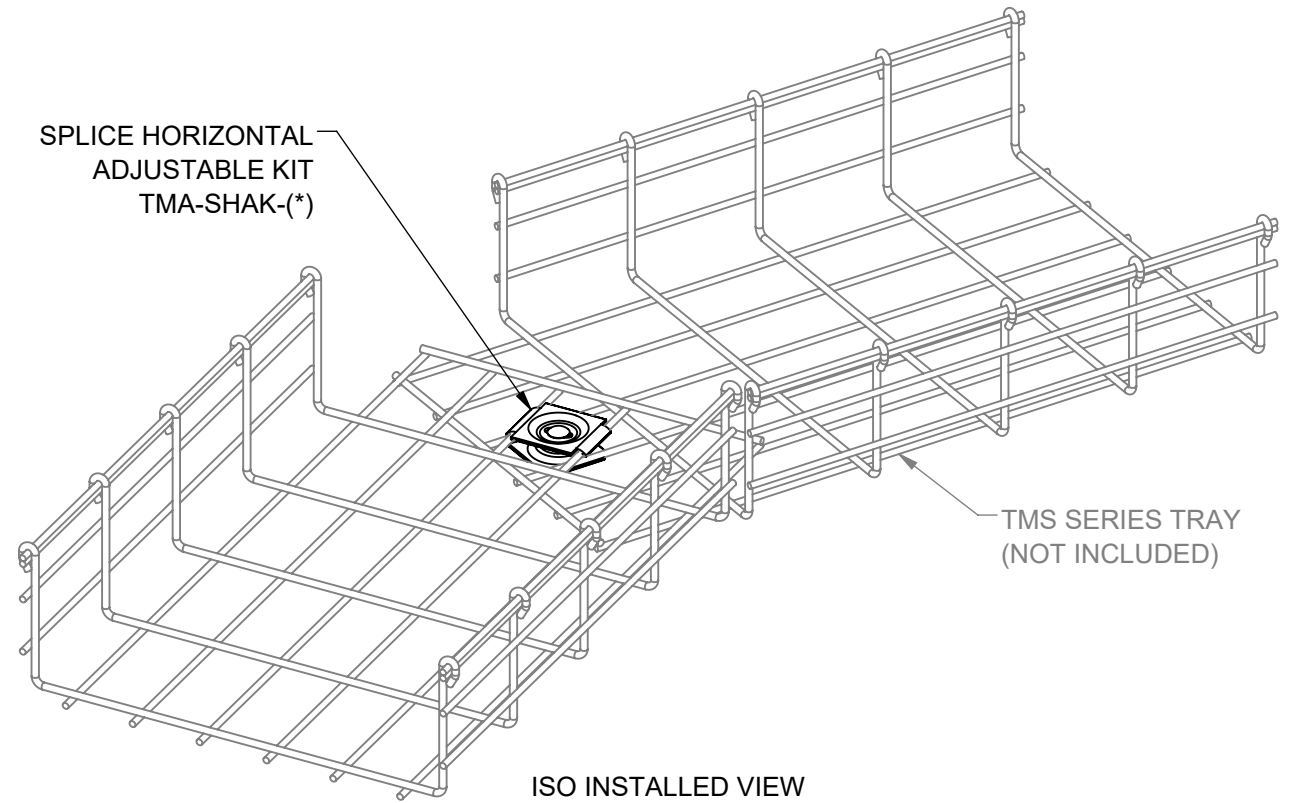

ISO INSTALLED VIEW

TMS SERIES TRAY
(NOT INCLUDED)

TMA - SHAK - EG

SERIES
TMA = TOUGHMESH
ACCESSORIES

TYPE
SHAK = SPLICE HORIZONTAL
ADJUSTABLE KIT

(*) MATERIAL/ FINISH
EG = ELECTROPLATED ZINC
PT = PAINTED
HD = HOT-DIPPED GALVANIZED
S4 = STAINLESS STEEL 304
S6 = STAINLESS STEEL 316

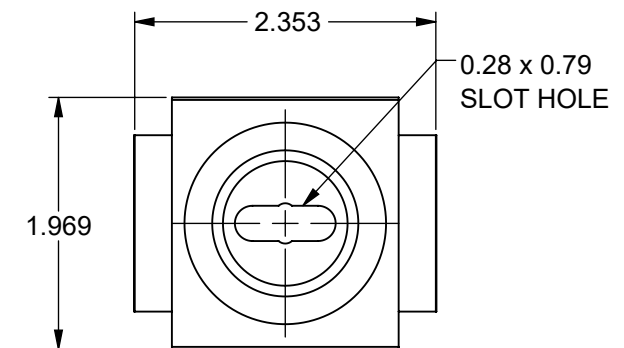

TOP VIEW

NOTE(S):

- 1) DIMENSIONS SHOWN ARE IN INCHES UNLESS OTHERWISE NOTED.
- 2) ALL DIMENSIONS SHOWN ARE NOMINAL.
- 3) PROVIDE SUPPORT WITHIN 2FT ON EACH SIDE OF THE SPLICE HORIZONTAL ADJUSTABLE KIT PER NEMA VE-2.
- 4) SOLD IN BAG OF 10.

PROPRIETARY AND CONFIDENTIAL THE INFORMATION CONTAINED IN THIS DRAWING IS THE SOLE PROPERTY OF CT INNOVATIONS. ANY REPRODUCTION IN PART OR AS A WHOLE WITHOUT THE WRITTEN PERMISSION OF CT INNOVATIONS IS PROHIBITED.

 CT INNOVATIONS	TITLE: TMA-SHAK-(*) TOUGHMESH SPLICE HORIZONTAL ADJUSTABLE KIT		
	DRAWN BY/DATE: LW 21OCT2024	SIZE: B	DWG. NO.: CTI-S37125
APPROVED BY/DATE: JDG 21OCT2024	SCALE: NTS	CAD FILE NAME: TMA-FLXW_A CAD SAVE DATE: Monday, October 21, 2024 6:03:11 PM	SHEET: 1 OF 1

6

5

4

3

2

1

6

5

4

3

2

1

F

F

E

E

D

D

C

C

B

B

A

A

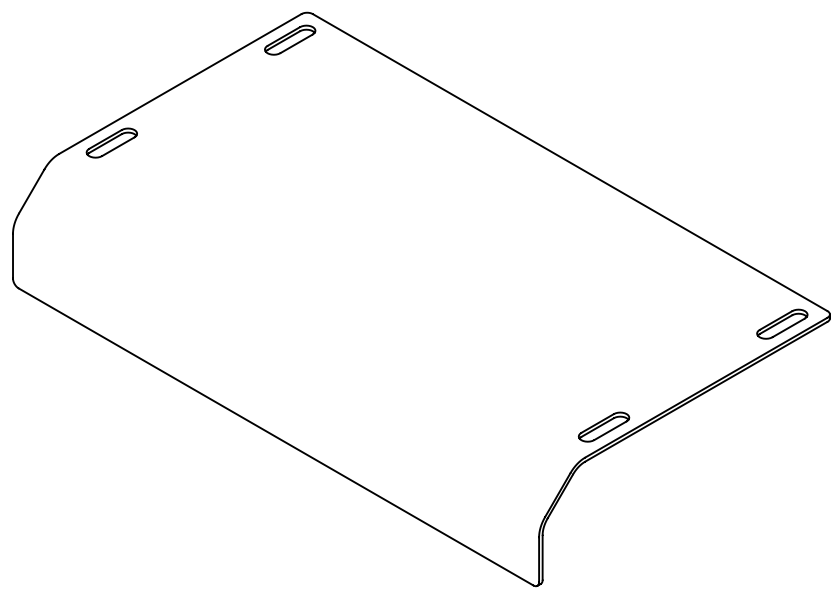

ISOMETRIC VIEW

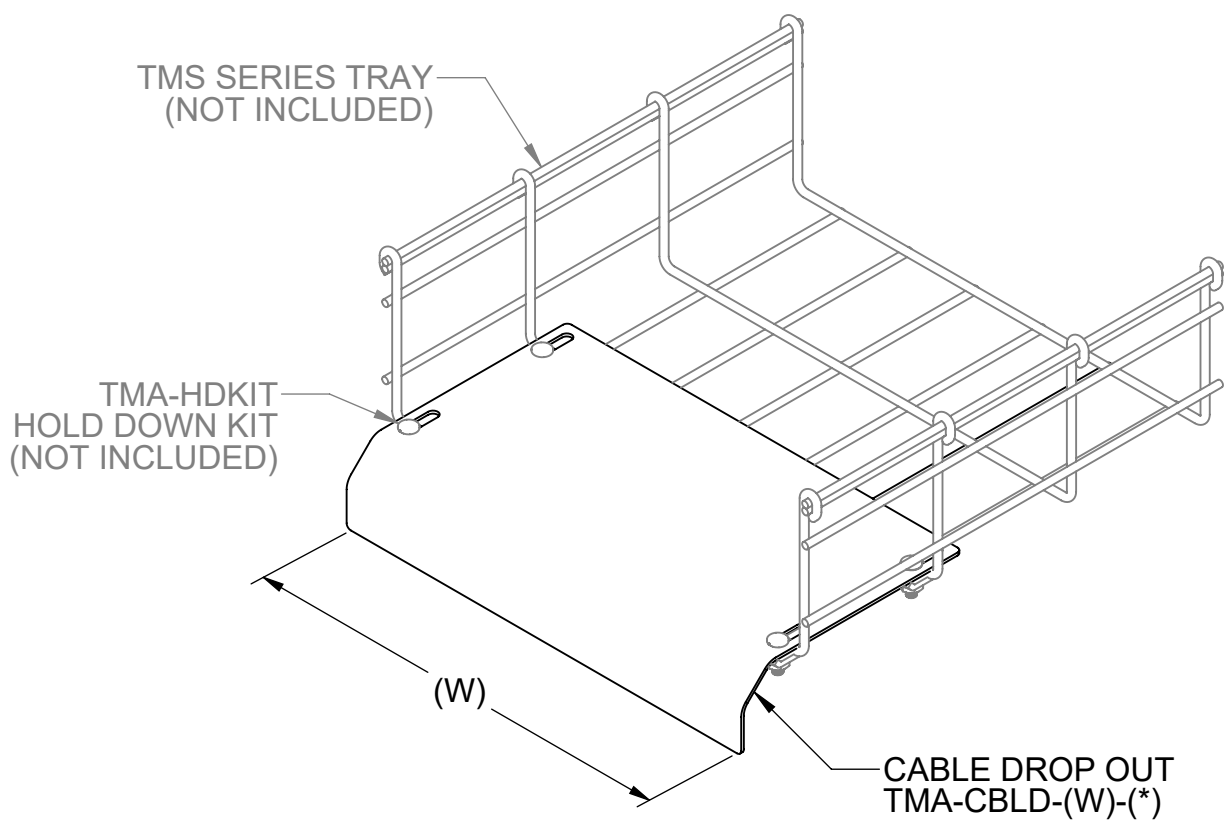

ISO INSTALLED VIEW

TMA - CBLD - 12 - EG

<p>SERIES TMA = TOUGHMESH ACCESSORIES</p>	<p>TYPE CBLD = CABLE DROP OUT</p>	<p>TRAY NOMINAL WIDTH 04 = 4" 06 = 6" 08 = 8" 10 = 10" 12 = 12" 16 = 16" 18 = 18" 20 = 20" 24 = 24"</p>	<p>(*) MATERIAL/ FINISH EG = ELECTROPLATED ZINC PT = PAINTED HD = HOT-DIPPED GALVANIZED S4 = STAINLESS STEEL 304 S6 = STAINLESS STEEL 316</p>
--	--	---	---

- NOTE(S):**
- 1) DIMENSIONS SHOWN ARE IN INCHES UNLESS OTHERWISE NOTED.
 - 2) ALL DIMENSIONS SHOWN ARE NOMINAL.
 - 3) CABLE DROP OUT IS USED FOR 2~6" HEIGHT & 4-24" WIDTH WIREBASKET TRAY.
 - 4) SOLD PER PIECE.
 - 5) FOUR (4) PIECES HOLD DOWN KIT "TMA-HDKIT-(*)" TO BE ORDERED SEPARATELY.

PROPRIETARY AND CONFIDENTIAL THE INFORMATION CONTAINED IN THIS DRAWING IS THE SOLE PROPERTY OF CT INNOVATIONS. ANY REPRODUCTION IN PART OR AS A WHOLE WITHOUT THE WRITTEN PERMISSION OF CT INNOVATIONS IS PROHIBITED.

 CT INNOVATIONS	TITLE: TOUGHMESH CABLE DROP OUT TMA-CBLD-(W)-(*)		
	DRAWN BY/DATE: DL 22APR2024	SIZE: B	DWG. NO.: CTI-S37990
APPROVED BY/DATE:	SCALE: NTS	CAD FILE NAME: TMA-CBLD-12_A CAD SAVE DATE: Monday, October 21, 2024 6:05:22 PM	SHEET: 1 OF 1

6

5

4

3

2

1